

# The Gibraltar Building Rules

**APPROVED DOCUMENT**

**R**

---

Access to and use of buildings

---

- R1 Access and use**
  - R2 Access to extensions to buildings other than dwellings**
  - R3 Sanitary conveniences in extensions to buildings other than dwellings**
  - R4 Sanitary conveniences in dwellings**
-



## Contents

Use of guidance .....	1
The Approved Documents .....	1
Other requirements .....	1
Materials and workmanship .....	1
Mixed Use Development .....	1
Disability Act 2017 and the Equal Opportunities Act 2006 .....	1
Exemptions.....	2
The Requirements .....	3
R1. Access and use .....	3
R2. Access to extensions to buildings other than dwellings.....	3
R3. Sanitary conveniences in extensions to buildings other than dwellings .....	3
R4. Sanitary conveniences in dwellings .....	3
Section O: general guidance .....	5
Performance.....	5
Where the requirements apply .....	5
Application of Part R.....	5
Extensions and structural alterations:.....	5
Dwellings .....	5
Extensions of non-dwelling buildings .....	6
Material change of use .....	7
Car parking and setting down.....	7
What requirements apply .....	7
Buildings other than dwellings .....	7
Dwellings .....	8
Buildings of Special Interest .....	9
Access statement.....	9
Definitions .....	10
Section 1: Access to buildings other than dwellings .....	12
Objectives.....	12
Level approach from the boundary of the site and car parking .....	12
Design considerations .....	12
Provisions .....	13
Onsite car parking and setting down .....	15
Design considerations .....	15
Provisions .....	15

---

Ramped access .....	16
Design considerations .....	16
Provision .....	16
Stepped access .....	17
Design considerations .....	17
Provisions .....	18
Handrails to external stepped and ramped access .....	22
Design considerations .....	22
Provisions .....	22
Hazards on access routes .....	24
Design considerations .....	24
Section 2: Access into buildings other than dwellings .....	25
Objectives .....	25
Accessible entrance .....	25
Provisions .....	25
Doors to accessible entrances .....	26
Design considerations .....	26
Provisions .....	26
Manually operated non-powered entrance doors .....	28
Design considerations .....	28
Powered entrance doors .....	28
Design considerations .....	28
Provisions .....	28
Design considerations .....	29
Provisions .....	29
Entrance lobbies .....	29
Design considerations .....	29
Provisions .....	30
Section 3: Horizontal and vertical circulation in buildings other than dwellings .....	32
Objective .....	32
Entrance hall and reception area .....	32
Design considerations .....	32
Provisions .....	32
Internal doors .....	33
Design considerations .....	33
Corridors and passageways .....	34
Design considerations .....	34

---

Internal lobbies .....	35
Design considerations .....	35
Vertical circulation within the building .....	35
Design considerations .....	35
Provision of lifting devices .....	36
Design considerations .....	36
Provisions .....	36
General requirements for lifting devices .....	36
Design considerations .....	36
Passenger lifts .....	37
Design considerations .....	37
Provisions .....	37
Lifting platforms.....	38
Design considerations .....	38
Provisions .....	39
Wheelchair platform stairlifts .....	40
Design considerations .....	40
Provisions .....	40
Internal stairs .....	40
Design considerations .....	40
Provisions .....	40
Internal ramps .....	41
Design considerations .....	41
Handrails to internal steps, stairs and ramps.....	41
Design considerations .....	41
Provisions .....	41
Section 4: Facilities in buildings other than dwellings .....	43
Objectives.....	43
Audience and spectator facilities .....	43
Design considerations .....	43
Provisions .....	44
Refreshment facilities .....	45
Design considerations .....	45
Provisions .....	45
Sleeping accommodation .....	47
Design considerations .....	47
Provisions .....	48

---

Switches, outlets and controls.....	50
Design considerations .....	50
Provisions .....	50
Aids to communication.....	51
Design considerations .....	51
Provisions .....	51
Section 5: Sanitary accommodation in buildings other than dwellings.....	53
Objectives.....	53
Sanitary accommodation generally .....	53
Design considerations .....	53
Provisions .....	53
Provision of toilet accommodation.....	54
Design considerations .....	54
Provisions .....	54
Wheelchair-accessible unisex toilets .....	55
Design considerations .....	55
Provisions .....	55
Toilets in separate-sex washrooms .....	59
Design considerations .....	59
Provisions .....	59
Wheelchair-accessible changing and shower facilities .....	60
Design considerations .....	60
Provisions .....	61
Wheelchair-accessible bathrooms .....	64
Design considerations .....	64
Provisions .....	64
Section 6: Means of access to and into the dwelling.....	67
Objective .....	67
Approach to the dwelling.....	67
Design considerations .....	67
Provisions .....	67
Level approach .....	68
Ramped Approach .....	68
Stepped approach.....	68
Approach using a driveway.....	68
Access into the dwelling.....	68
Provisions .....	69

---

Entrance doors.....	69
Design considerations .....	69
Provisions .....	69
Section 7: Circulation within the entrance storey of the dwelling .....	70
Objective .....	70
Corridors, passageways and internal doors within the entrance storey .....	70
Design considerations .....	70
Provisions .....	70
Vertical circulation within the entrance .....	71
storey .....	71
Design considerations .....	71
Section 8: Accessible switches and socket outlets in the dwelling.....	72
Objective .....	72
Design considerations .....	72
Provisions .....	72
Section 9: Passenger lifts and common stairs in blocks of flats .....	73
Objectives.....	73
Design Considerations .....	73
Provisions .....	73
Lifts.....	74
Section 10: WC provision in the entrance storey of the dwelling .....	75
Objectives.....	75
Design considerations .....	75
Provision.....	75

---

---

# Use of guidance

---

## The Approved Documents

This document has been approved and issued by H M Government of Gibraltar for the purpose of providing practical guidance as an addition to the Building Rules 2017.

This document is intended to provide guidance for some of the more common building situations. However, there may well be alternative ways of achieving compliance with the requirements. **Thus there is no obligation to adopt any particular solution contained in this document if you prefer to meet the relevant requirement in some other way, provided that the alternative solutions have the approval of building control.**

## Other requirements

The guidance contained in this document relates only to Part R of the Building Rules 2017. Any building work that is carried out will also have to comply with the other requirements found in the Building Rules 2017.

## Materials and workmanship

Any building work which is subject to the requirements imposed under Part B of the Building Rules 2017 should be carried out with proper materials and in a workmanlike manner.

When an Approved Document makes reference to a named standard, the relevant version of the standard applies. However, if this version has

been revised or updated by the issuing standards body, the new version may be used as a source of guidance provided it continues to address the relevant requirements of the Rules.

The appropriate use of a product which complies with a European Technical Approval as defined in the Construction Products Directive will meet the relevant requirements.

## Mixed Use Development

In mixed use developments part of a building may be used as a dwelling while another part has a non-dwelling use. In such cases, if the requirements of the Rules for dwellings and non-dwelling use differ the requirements for non-dwelling use should apply in any shared parts of the building.

## Disability Act 2017 and the Equal Opportunities Act 2006

The legislation relating to the rights of disabled persons and to the general establishment of equality are found in the Disability Act 2017 and the Equal Opportunities Act 2006. Both these pieces of legislation contain considerations that should be taken into account regarding aspects such as the accessibility to buildings for disabled persons.

The Disability Act 2017 is modelled on the UN Convention on the rights of persons with disabilities. This contains requirements and considerations that



may have an effect on building design and should be considered.

The Equal Opportunities Act 2006 aims to strengthen and harmonise equality legislation, primarily from an employment and training perspective, in order to deliver better outcomes for the protected groups listed, which includes disabled persons.

Although the guidance in this document, if followed tends to demonstrate compliance with Part R of the Building Rules 2017, this does not necessarily equate to compliance with the considerations, obligations and duties set out in the Disability Act 2017 and the Equal Opportunities Act 2006. This is because service providers and employers are required to make reasonable adjustments to any physical feature that might put a disabled person at a substantial disadvantage compared to a non-disabled person. In some instances this will include designing features that are outside the scope of the Approved Document. It

remains for the persons undertaking building works to consider if further provisions, beyond that described in the Approved Document are appropriate. Furthermore any concept of building design must keep in mind the accessibility of disabled persons to gain access to buildings and to use the facilities on offer, so that their participation in everyday life is inclusive and promotes equality.

## **Exemptions**

Rule A5 prescribes those buildings to which the rules do not apply. However, it will be considered practical to adopt the requirements of this part to existing buildings which may reasonably adopt physical features to assist access to the building which will improve the manoeuvrability to persons with limited mobility.

---

## The Requirements

---

---

### Requirement

---

### Limits on application

---

#### PART R ACCESS TO AND USE OF BUILDINGS

The requirements of this Part do not apply to:

#### R1. Access and use

Reasonable provision shall be made for people to:

- (a) gain access to; and
- (b) use

the building and its facilities.

- (a) an extension or a structural alteration of a dwelling; or
- (b) any part of a building which is used solely to enable the building or any service or fitting in the building to be inspected, repaired or maintained.

#### R2. Access to extensions to buildings other than dwellings

Suitable independent access shall be provided to the extension where reasonably practicable.

Requirement R2 does not apply where suitable access to the extension is provided through the building that is extended.

#### R3. Sanitary conveniences in extensions to buildings other than dwellings

If sanitary conveniences are provided in any building that is to be extended, reasonable provision shall be made within the extension for sanitary conveniences.

Requirement R3 does not apply where there is reasonable provision for sanitary conveniences elsewhere in the building, such that people occupied in or otherwise having occasion to enter the extension, can gain access to and use those sanitary conveniences.

#### R4. Sanitary conveniences in dwellings

(1) Reasonable provision shall be made in the entrance storey for sanitary conveniences, or where the entrance storey contains no habitable rooms, reasonable provision for sanitary conveniences shall be made in either the entrance storey or the principal storey.

(2) In this paragraph 'entrance storey' means the storey which contains the principal entrance and 'principal storey' means the storey nearest to the entrance storey which contains a habitable room, or if there are two such storeys equally near, either such storey.

## Notes

**Means of escape in case of fire:** the scope of Part R is limited to matters of access to, into and use of a building. It does not extend to means of escape in the event of fire, for which reference should be made to – Part E ‘Safety in Fire’.

**Stairs and ramps:** Part H – Stairways, ramps, balustrades and vehicle barriers, contains general guidance for steps, stairs and ramps when they are part of a building. Additional guidance is provided in this document when external stepped and ramped accesses also form part of the principal entrances and alternative accessible entrances, and when they form part of the access route to the building from the boundary of the site and car parking.

- **BS 8300-1:2018 - Design of an accessible and inclusive built environment. External environment and**
- **BS 8300-2:2018 - Design of an accessible and inclusive built environment. Buildings.** BS 8300 series provides guidance on good practice in the design of dwellings and non-dwelling buildings and their approaches so that they are convenient to use by disabled people. The design recommendations are based on user trials and validated desk studies which formed part of a research project commissioned in 1997 and 2001 by DETR. The guidance in this Approved Document is based on and is complementary to the BS, although the BS contains much additional material that is not apt for, or not considered appropriate for, inclusion in guidance accompanying regulation. Also, in a few cases, the guidance in Approved Document R differs from the recommendation in BS 8300. Compliance with the recommendations in the BS, therefore, while ensuring good practice, is not necessarily equivalent to compliance with the guidance in Approved Document R.

---

## Section O: general guidance

---

### Performance

In the Government's view the requirements of Part R will be met by making reasonable provision to ensure that buildings are accessible and usable.

People, regardless of disability, age or gender, should be able to:

- a. gain access to buildings and to gain access within buildings and use their facilities, both as visitors and as people who live or work in them;
- b. use sanitary conveniences in the principal storey of a new dwelling.

The provisions are expected to enable occupants with disabilities to cope better with reducing mobility and to 'stay put' longer in their own homes. The provisions are not necessarily expected to facilitate fully independent living for all people with disabilities.

### Where the requirements apply

#### Application of Part R

**0.1** The requirements apply if:

- a. a non-dwelling building or a dwelling is newly erected;
- b. an existing non-dwelling building is extended, or undergoes a structural alteration and in the case of a dwelling, only where the extension or structural alteration results in a new or greater contravention of Part R; or
- c. an existing building or part of an existing building undergoes a

material change of use in accordance with a case described in Rule A9.

It should be noted that, regardless of compliance with the Building Rules 2017, there will be obligations under the Disability Act 2017 for service providers and employers to consider barriers created by physical features in buildings.

#### Extensions and structural alterations:

##### Dwellings

**0.2** Under Rule A7, where any building is extended, or undergoes a structural alteration, the building work must be carried out so that after it has been completed the extension or structural alteration of the building complies with the applicable requirements of the Building Rules 2017, or, where it did not fully comply with any applicable requirement there is no new or greater contravention of any rule.

**0.3** This rule applies to dwellings as well as to non-dwelling buildings. Under the Limits on Application in Part R, Part R does not apply to an extension or structural alteration of a dwelling. However, an extension of a dwelling, or a structural alteration of a dwelling, must not result in the building being in a new or greater contravention of Part R than it was before.

**0.4** Under Rule A9 the expression 'material change of use' is defined. Where there is a material change of use, the building must comply with Part R - This will extend to material changes of use resulting in the creation of a dwelling. Under the general limits on application of Part R, the requirements of that Part do not apply to an extension of or a structural alteration of a dwelling. This means that the extension or alteration work itself need not comply with Part R. However, a

planned alteration to a dwelling that has the potential to reduce the compliance of the dwelling as a whole with Part R must be carried out in such a way that there is no new or greater contravention of Part R. Similarly, an extension of a dwelling need not itself comply with Part R, but it must not result in the dwelling having a new or greater contravention of Part R. The following examples illustrate these points.

**Example 1:** a planned project involving removal of a WC in the entrance storey of a dwelling would be a structural alteration if it is the only WC in that storey and the storey contains habitable rooms. The WC must not be removed or result in a new or greater contravention with Part R, unless another WC is provided in the entrance storey that itself does not result in a new or greater contravention in terms of compliance with Part R than the old one.

**Example 2:** a planned extension enclosing the principal entrance of a dwelling must not result in the dwelling exhibiting a new or greater contravention of requirement R1 than before. It must be no less easy for people, including disabled people, to gain access to the dwelling, either via the extension and the original entrance point, or (subject to the guidance in Section 6 of this Approved Document) via a suitable alternative entrance.

### **Extensions of non-dwelling buildings**

**0.5** An extension to a non-dwelling building should be treated in the same manner as a new building, as regards its own compliance with Part R. Under the new Requirement R2 there must be suitable independent access to the extension where reasonably practicable. Under the Limits on Application, Requirement R2 does not apply where the building that is extended complies with Requirement R1 (a) so as to provide suitable access through the building to the extension. The concept of access encompasses access from the boundary

of the site and from on-site car parking where provided.

**0.6** If the owners of a building prefer not to provide independent access to a planned extension, it is open to them either to demonstrate that the existing building and the approach to it already comply with Requirement R1 (a), that the Limit on Application of Requirement R2 applies, or to modify the existing building and/or the approach to it so that the Limit on Application applies. Such modification work would be a structural alteration. The extension and the alterations of the existing building could be planned and carried out as a single project.

**0.7** In judging whether access provision relying on the existing building is sufficient for the Limit on Application of Requirement R2 to apply, and in judging whether it is reasonably practicable for suitable independent access to be provided, practical constraints and cost considerations will be relevant – see also 'Access Statements' paragraphs 0.18 to 0.23 below.

**0.8** Under new Requirement R3, if sanitary conveniences are provided in any building that is to be extended; reasonable provision must be made within the extension for sanitary conveniences. However, under the Limit on Application of Requirement R3, this requirement does not apply if there is reasonable provision for people using the extension to gain access to and to use sanitary conveniences in the existing building. As in the case of access to an extension, it is open to building owners preferring not to make provisions for sanitary conveniences in a planned extension either to demonstrate that reasonable provision already exists in, or to modify, the existing building so that the Limit on Application of Requirement R3 applies. In this case, too, the extension and the modifications to the existing building could be planned and carried out as a single project.

**0.9** Building work must comply, where relevant, with the key requirements in the

Building Rules 2017 and the Approved Documents for the purposes of those Rules. This means that alterations to features relevant to the compliance of a building with Part R, such as entrances or arrangements for people to get from one level to another within the building, must result in features that comply with Requirement R1. Where new features relevant to the compliance of a building with Part R are provided, these must also comply with Requirement R1. Reasonable provision must be made for people to gain access to and to use new or altered sanitary conveniences. The building as a whole, including access to it from the site boundary and from on-site car parking where provided, must be no less compliant with Requirement R1 following a material change of use of a building. In the context of a structural alteration of a building, it is not necessary, as regards the Building Rules 2017, to upgrade access to the building entrance from the site boundary and from on-site car parking where provided.

### **Material change of use**

**0.10** Under Rule A9, where there is a material change of use which falls under one of the listed cases, the building must be upgraded, if necessary, so as to comply with R1 (Access and use) as well as other relevant Requirements depending on whether the building is a dwelling, non-dwelling or mixed use development.

**0.11** Under Rule A9 if an existing building undergoes a material change of use which falls under one of the listed cases, such work if any shall be carried out as is necessary to ensure that:

- there is reasonable provision for people to gain access to that part from the site boundary and from on-site car parking where provided, either by means of an independent access or by means of a route to and through the building;

- that part itself complies with R1 (access and use); and
- any sanitary conveniences provided in, or in connection with Requirement R1: if users of that part have the use of sanitary conveniences elsewhere in the building, there must be reasonable provision for people to gain access to use that sanitary accommodation, upgraded if need be.

Developers will need to agree how they have assessed what is reasonable provision with Building Control as set out in paragraphs 0.18 to 0.23

**0.12** Where a material change of use results in a building being used in part as a hotel or boarding house, institution, public building or shop, and in part as a dwelling, regard should be had to the guidance in Sections 1 to 5 of this Approved Document in relation to the relevant non-dwelling accommodation and to the common parts (see also MIXED USE DEVELOPMENT under Use of Guidance).

### **Car parking and setting down**

**0.13** Part R applies to those features, outside the building, which are needed to provide access to the building from the edge of the site and from car parking and setting down points within the site.

### **What requirements apply**

**0.14** If Part R applies, reasonable provision should be made in:

### **Buildings other than dwellings**

- a. so that people, regardless of disability, age or gender, can reach the principal entrance to the building and other entrances

- described in this Approved Document from the site boundary, from car parking within the site, and from other buildings on the same site (such as a university campus, a school or a hospital);
- b. so that elements of the building do not constitute a hazard to users, especially people with impaired sight, but rather assist in wayfinding;
  - c. so that people, regardless of disability, age or gender, can have access into, and within, any storey of the building and to the building's facilities, subject to the usual gender-related conventions regarding sanitary accommodation;
  - d. for suitable accommodation for people in wheelchairs, or people with other disabilities, in audience or spectator seating;
  - e. for aids to communication for people with an impairment of hearing or sight in auditoria, meeting rooms, reception areas, ticket offices and at information points; and
  - f. for sanitary accommodation for the users of the building.
- principal storey of the dwelling; and
- c. for WC provision at no higher storey than the principal storey.

## Dwellings

- a. so that people, including disabled people, can reach the principal, or suitable alternative, entrance to the dwelling from the point of access.
- b. so that people, including disabled people, can gain access into and within the

## Buildings of Special Interest

**0.15** Buildings of special interest include:

- a. listed buildings,
- b. buildings which are of architectural and historic interest,
- c. buildings of architectural and historic interest within the nature reserve, and world heritage sites,
- d. vernacular buildings of traditional form and construction.

**0.16** The need to conserve the special characteristics of buildings of special interest must be recognised. They are a finite resource with cultural importance. In such work the aim should be to improve accessibility where and to the extent that it is practically possible, always provided that the work does not prejudice the character of the historic building, or increase the risk of long-term deterioration to the building fabric or fittings. In arriving at an appropriate balance between historic building conservation and accessibility, it would be appropriate to take into account the advice of the person or body responsible for buildings of special interest, approved by the Government, in order to make the building as accessible as possible.

**0.17** Particular issues relating to work in buildings of special interest that warrant sympathetic treatment and where advice from others could therefore be beneficial include:

- a. restoring the historic character of a building that had been subject to previous inappropriate alteration, e.g. replacement windows, doors and rooflights;
- b. rebuilding a former historic building (e.g. following a fire or filling in a gap site in a terrace);

- c. the choice of appropriate construction materials and techniques, e.g. making provisions enabling the fabric to 'breathe' to control moisture and potential long-term decay problems.

## Access statement

**0.18** It is important that applicants clearly communicate to Building Control how their chosen approach to meeting the accessibility needs of the likely end-users of a building and its facilities demonstrates compliance with the requirements of Part R. The guidance in this Approved Document is designed to indicate only one way in which those requirements may be met. Whilst alternative, equally satisfactory ways of meeting the requirements can be adopted depending on the size, scale, nature and intended use of the building they must still demonstrate compliance with the relevant functional requirement.

**0.19** Where alternative solutions are proposed, the onus remains with the applicant to demonstrate that those solutions are appropriate and meet the requirements, for example by showing that it is equivalent to the provisions set out in the Approved Document. This should include the use of appropriate research evidence or reference to recognized British Standards as necessary to support the chosen approach. It is advisable to ensure that the appropriate level of provision is agreed with Building Control prior to commencing building works, as retrospective alterations can be costly and disruptive.

**0.20** Applicants should therefore seek to engage with Building Control at the earliest possible stage to identify key issues and risks and to discuss the best way to demonstrate the access strategy for the building work taking place. To ensure satisfactory outcomes, communication between applicants and Building Control should focus on areas where proposals diverge from the guidance in this Approved Document rather than providing an



exhaustive explanation where features are in accordance with the guidance.

**0.21** Provision of a written Access strategy is not required to accompany a Building Control application though it may be useful in some circumstances. The key focus should be on ensuring that applicants and Building Control are agreed as to the appropriate level of provision in the completed building work.

**0.22** In smaller or simpler works this could be achieved by having a conversation to review the proposals and recoding the outcome of discussions by correspondence. In large complex works or where there are significant constraints imposed by an existing site, this might involve a written document setting out key aspects of the access approach, supported by annotated drawings as well as face to face meetings to resolve key issues. It is for the Building Control Section and applicant to agree which, if any of these proposed approaches should be used on a case by case basis to ensure that the functional requirements of Part R are satisfied. Whichever approach is adopted, the agreed level of provision should be clearly recorded.

**0.23** It should be noted that approval of proposed works by Building Control does not by necessity indicate compliance with duties under The Equal Opportunities Act 2006 or the Disability Act 2017. Applicants need to consider equality obligations when undertaking building work and whether provision in some circumstances should exceed that set out within the Approved Document.

## Definitions

**0.24** The following meanings apply to terms throughout this Approved Document.

**Contrast visually**, when used to indicate the visual perception of one element of the building, or fitting within the building, against another means that the difference in light

reflectance value between the two surfaces is greater than 30 points.

**General access stair**, a stair intended for all users of a building on a day-to-day basis, as normal route between levels.

**Illuminance**, the amount of light falling on a surface, measured in lumens per square meter ( $\text{lm}/\text{m}^2$ ) or lux (lx).

**Level**, with respect to the surfaces of a level approach, access routes and landings associated with steps, stairs and ramps means predominantly level, but with a maximum gradient along the direction of travel of 1:60.

**Light reflectance value (LRV)**, the total quantity of visible light reflected by a surface at all wavelengths and directions when illuminated by a light source.

**Principal entrance**, the entrance which a visitor not familiar with the building would normally expect to approach.

**Suitable**, with respect to means of access and facilities, means that they are designed for use by people regardless of disability, age or gender, but subject to the usual gender-related conventions regarding sanitary accommodation.

**Usable**, with respect to buildings or parts of buildings, means that they are convenient for independent use.

**Utility stair**, a stair used for escape, access for maintenance, or purposes other than as a usual route for moving between levels on a day-to-day basis.

**0.25** The following means apply only to terms used in the sections on dwellings in this Approved Document.

**Common**, serving more than one dwelling.

**Habitable room**, for the purpose of defining the principal storey, means a room used, or

intended to be used, for dwelling purposes, including a kitchen but not a bathroom or a utility room.

**Maisonette**, a self-contained dwelling, but not a dwelling-house, which occupies more than one storey in a building.

**Point of access**, the point at which a person visiting a dwelling would normally alight from a vehicle which may be within or outside the plot, prior to approaching the dwelling.

**Plot gradient**, the gradient measured between the finished floor level of the dwelling and the point of access.

**Steeply sloping plot**, a plot gradient of more than 1:15.

---

## Section 1: Access to buildings other than dwellings

---

### Objectives

**1.1** The aim is to provide a suitable means of access for people from the entrance point at the boundary of the site, and from any car parking that is provided on the site, to the building. It is also important that routes between buildings within a complex are also accessible.

**1.2** In designing an approach to the building, it should be recognized that changes in level are difficult for many people to negotiate, including wheelchair users, people who need to use walking aids and people with impaired sight. Access routes that are too narrow can also make it difficult for people to pass each other.

**1.3** It is important to be aware that people's capabilities vary. For example, for some people, a stair is easier to use than a ramp.

**1.4** The building should be designed, within the overall constraints of space, so that the difference in level between the entrance storey and the site entry point is minimized.

**1.5** It is also important that potential hazards on access routes adjacent to buildings, e.g. open windows, are avoided so that people, particularly children and those with impaired sight or hearing, are not injured.

**Note:** The publication 'Inclusive Mobility: A Guide to Best Practice on Access to Pedestrian and Transport Infrastructure' gives detailed guidance on designing the external environment and BS 8300.

### Level approach from the boundary of the site and car parking

#### Design considerations

**1.6** As far as possible, access should be level from the boundary of the site, and from any car parking designated for disabled people, to the principal entrance and any entrance used exclusively for staff or, if either of these is not accessible, to any alternative accessible entrances. If access is generally required between entrances, or between alternative accessible entrances outside the building, this access should as far as possible be level. The site level of accessible entrances should be determined accordingly.

**1.7** Where a difference in level between the boundary of the site or car parking designated for disabled people and the building is unavoidable due to site constraints, the approach may have a gentle gradient over a long distance (for all or part/s of the approach) or it may incorporate a number of shorter parts at a steeper gradient, with level landings at intervals as rest points. Generally, gradients within the approach should be gentle as possible.

**1.8** Where the gradient of the approach, whether over its whole length or in part, is 1:20 or steeper, that part of the approach should be designed as ramped access.

**1.9** All access routes to principal, or alternative accessible, entrances should be surfaced so that people are able to travel along them easily, without excessive effort and without the risk of tripping or falling.

**1.10** There should be sufficient space for people to approach the building, pass others who are travelling in the opposite direction and carry out all necessary manoeuvres.

**1.11** A surface width of 1800mm can accommodate any amount of non-vehicular traffic without the need for passing places. A surface width of 1200mm may be acceptable

on restricted sites, subject to agreement with Building Control.

**1.12** It is important to reduce the risks to people, particularly people with impaired sight, when approaching and passing around the perimeter of the building under all lighting conditions.

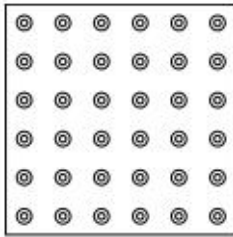
### Provisions

**1.13** A 'level approach' (from the boundary of the site and from car parking spaces designated for disabled people to the principal entrance, to a staff entrance or to an alternative accessible entrance) will satisfy Requirement R1 or R2 if:

- (a) it has a surface width of at least 1.5m, with passing places, free of obstructions to a height of 2.1m;
- (b) passing places at least 1.8m wide and at least 2m long are provided within sight of each other (the width of the passing place may be included in the width of the level approach), but in any case spaced at a distance no greater than 50m;
- (c) the gradient along its length is either no steeper than 1:60 along its whole length, or less steep than 1:20 with level landings (see 1.26(k)) introduced for each 500mm rise of the access (where necessary, between landings), in all cases with a cross-fall gradient no steeper than 1:40;
- (d) its surface is firm, durable and slip resistant, with undulations not exceeding 3mm under a 1m straight edge for formless materials. Inappropriate materials might be loose sand or gravel;
- (e) where there are different materials along the access route, they have similar frictional characteristics;

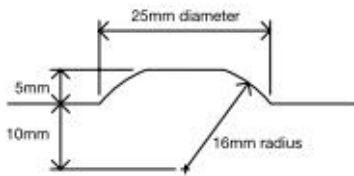
- (f) the difference in level at joints between paving units is not greater than 5mm, with joints filled flush or, if recessed, no deeper than 5mm and no wider than 10mm or, if unfilled, no wider than 5mm;
- (g) the route to the principal entrance (or alternative accessible entrance) is clearly identified and well lit;
- (h) the danger of inadvertently walking into a vehicular access route is minimized by providing a separate pedestrian route and, where there is an uncontrolled crossing point across the vehicular route, this is identified by a buff coloured blister surface (see Diagram 1, and 'Guidance on the use of Tactile Paving Surfaces').

**Diagram 1 - Tactile paving and an example of its use at an uncontrolled crossing**

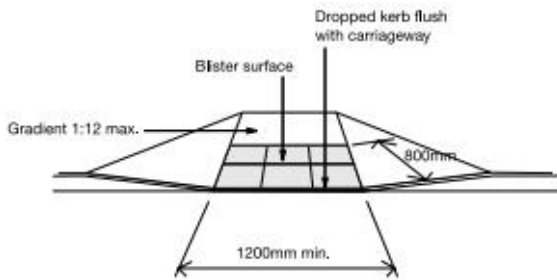


**Blister surface** (with 36 domes)

Note: Full details of tactile paving are in "Guidance on the use of Tactile Paving Surfaces."



**Dome profile**



**Dropped kerb at an uncontrolled crossing**

## Onsite car parking and setting down

### Design considerations

**1.14** People who need to travel to buildings by car need to be able to park, have sufficient space to enter and leave their vehicle, on occasions move to the rear of their vehicle, then walk, travel in a wheelchair or with pushchairs or luggage, etc. to any alternative accessible entrance of the building.

**1.15** The surface of a parking bay designated for disabled people, in particular the area surrounding the bay, should allow the safe transfer of a passenger or driver to a wheelchair and transfer from the parking bay to the access route to the building without undue effort, barriers to wheelchairs or hazards from tripping.

**1.16** If people need to obtain tickets for pay and display parking, the ticket dispensing machines should be located in a way that allows a person in a wheelchair, or a person of short stature, to gain access close to the machine and reach the payment and ticket dispensing functions.

**1.17** People with mobility impairments who arrive as passengers should be able to alight from a vehicle close to the principal entrance, or alternative accessible entrance, of the building in a way that is convenient for entry into the building.

Note: Guidance is available in BS 8300 on:

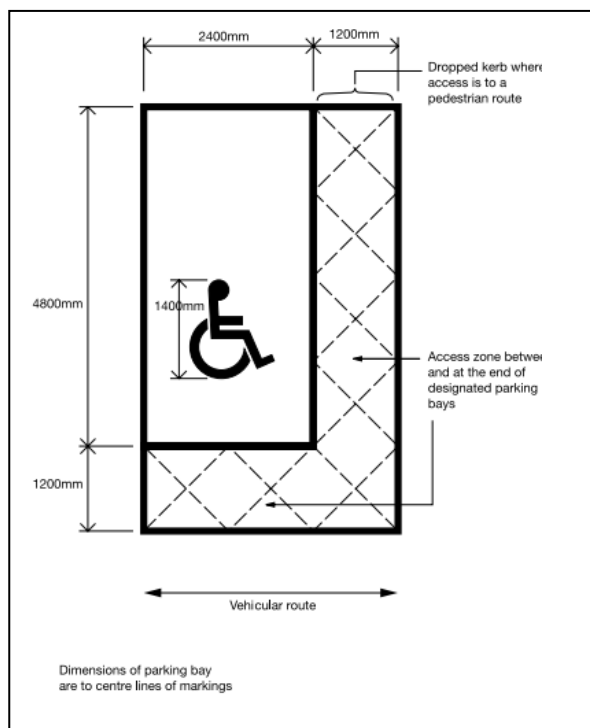
- The provision of parking bays designated for disabled people in different building types;
- ticket dispensing machines;
- vehicular control barriers; and
- multi-storey car parks.

### Provisions

**1.18** Car parking and setting down will satisfy Requirement R1 or R2 if:

- at least one parking bay designated for disabled people is provided on firm and level ground as close as feasible to the principal entrance of the building;
- the dimensions of the designated parking bays are as shown in Diagram 2 (with a 1200mm accessibility zone between, and a 1200mm safety zone on the vehicular side of, the parking bays, and with a dropped kerb when there is a pedestrian route at the other side of the parking bay);
- the surface of the accessibility zone is firm, durable and slip resistant, with undulations not exceeding 3mm under a 1m straight edge for formless materials. Inappropriate materials might be loose sand or gravel;

**Diagram 2 – Parking bay designated for disabled people**



- d. ticket machines, where necessary for wheelchair users and people of short stature, are adjacent to the designated parking bays for disabled people and have controls between 750mm and 1200mm above the ground and a plinth which does not project in front of the face of the machine in a way that prevents its convenient use;
- e. a clearly sign-posted setting down point is located on firm and level ground as close as practicable to the principal or alternative accessible entrance with its surface level with the carriageway at that point to allow convenient access to and from the entrance for people with walking difficulties or people using a wheelchair.

## Ramped access

**Note:** Where there appears to be a conflict between the guidance in Part R and Part H, Part R takes precedence; see the Notes to the Requirements.

## Design considerations

**1.19** If site constraints necessitate an approach of 1:20 or steeper, an approach incorporating ramped access should be provided. Ramps are beneficial for wheelchair users and people pushing prams, pushchairs and bicycles.

**1.20** Gradients should be as shallow as practicable, as steep gradients create difficulties for some wheelchair users who lack the strength to propel themselves up a slope or have difficulty in slowing down or stopping when descending. Consideration should be given to use this exclusively for shop refurbishments only.

**1.21** Ramps are also not necessarily safe and convenient for ambulant disabled people. For

example, some people who can walk but have restricted mobility find it more difficult to negotiate a ramp than a stair. In addition, adverse weather conditions increase the risk of slipping on a ramp. It is therefore beneficial to have steps as well as a ramp.

**1.22** Some people need to be able to stop frequently; for instance to regain strength or breath, or to ease pain.

**1.23** Wheelchair users need adequate space to stop on landings, to open and pass through doors without having to reverse into circulation routes or to face the risk of rolling back down slopes.

**1.24** Some people have a weakness on one side. This leads to a requirement for support at both sides of ramps.

**1.25** If the total rise of a ramped approach is too high, it can be unacceptably tiring for wheelchair users and some people with walking difficulties, even if a number of rest landings are provided.

**Note:** Guidance is given in BS 8300 on: lighting ramped access.

## Provision

**1.26** A ramped access will satisfy Requirement R1 or R2 if:

- a. either it is readily apparent or the approach to it is clearly sign-posted;
- b. the gradient of a ramp flight and its going between landings are in accordance with Table 1 and Diagram 3;
- c. no flight has a going greater than 10m, or a rise of more than 500mm;
- d. there is an alternative means of access for wheelchair users, e.g. a lift, when the total rise is greater than 2m;

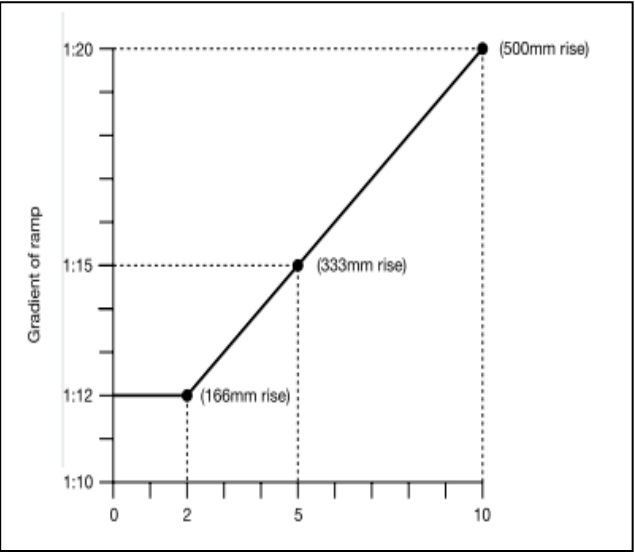
- e. it has a surface width between walls, upstands or kerbs of at least 1.5m;
- f. the ramp surface is slip resistant, especially when wet, and of a colour that contrasts visually with that of the landings;
- g. the frictional characteristics of the ramp and landing surfaces are similar;
- h. there is a landing at the foot and head of the ramp at least 1.2m long and clear of any door swings or other obstructions;
- i. any intermediate landings are at least 1.5m long and clear of any door swings or other obstructions;
- j. intermediate landings at least 1800mm wide and 1800mm long are provided as passing places when it is not possible for a wheelchair user to see from one end of the ramp to the other or the ramp has three flights or more;
- k. all landings are level, subject to a maximum gradient of 1:60 along their length and a maximum cross-fall gradient of 1:40;
- l. there is a handrail on both sides;
- m. there is a kerb on the open side of any ramp or landing at least 100mm high, which contrasts visually with the ramp or landing in addition to any guarding required under Part H;
- n. clearly sign-posted steps are provided, in addition, when the rise of the ramp is greater than 300mm equivalent to 2 x 150mm steps).

**Table 1 – Limits for ramp gradients**

Going of flight	Maximum gradient	Maximum rise
10m	1:20	500mm
5m	1:15	333mm
2m	1:12	166mm

**Note:**  
For goings between 2m and 10m, it is acceptable to interpolate between the maximum gradients, i.e. 1:14 for a 4m going or 1:19 for a 9m going (see diagram3)

**Diagram 3 – Relationship of ramp gradient to the going of a flight**



**Stepped access**

**Note:** Where there appears to be a conflict between the guidance in Part R and Part H, Part R takes precedence; see the Notes to the Requirements.

**Design considerations**

**1.27** People with impaired sight risk tripping or losing their balance if there is no warning



that steps provide a change in level. The risk is most hazardous at the head of a flight of steps when a person is descending.

**1.28** The warning should be placed sufficiently in advance of the hazard to allow time to stop and not be so narrow that it might be missed in a single stride.

**1.29** Materials for treads should not present a slip hazard, especially when the surface is wet.

**1.30** People should be able to appreciate easily where to place their feet by highlighting nosings and avoiding open risers.

**1.31** People who wear callipers or who have stiffness in hip or knee joints are particularly at risk of tripping or catching their feet beneath nosings. People with a weakness on one side or with sight impairment need the dimensions of the tread to be sufficient for them to be able to place their feet square onto it. If the going is towards the upper end of the dimensional range, the flight may rise to a greater height without the need for an intermediate landing, as the tread is sufficiently deep to allow a person to stand and rest at any point within the flight. It should be noted that excessive rounding of nosings reduces the effective going.

**1.32** Many ambulant disabled people find it easier to negotiate a flight of steps than a ramp and, for these people, the presence of handrails for support is essential.

**Note:** Guidance is given in BS 8300 on:

- lighting stepped access; and
- slip resistance.

## Provisions

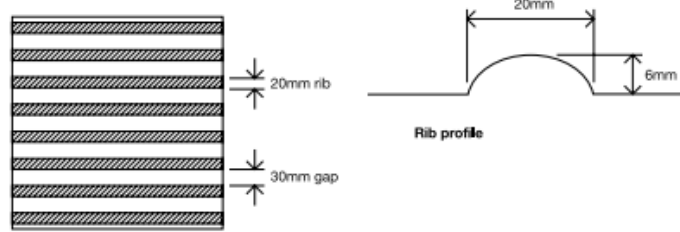
**1.33** A stepped access will satisfy requirement R1 or R2 if:

- a. a level landing is provided at the top and bottom of each flight;
- b. the unobstructed length of each landing is not less than 1200mm;
- c. a 'corduroy' hazard warning surface is provided at top and bottom landings of a series of flights to give advance warning of a change in level in accordance with Diagram 4;
- d. where there is side access onto an intermediate landing, a 'corduroy' hazard warning surface 400mm deep is provided either on the intermediate landing 400mm from both upper and lower flights, if there is sufficient space to accommodate the surface outside the line of the side access, or within the side access 400mm from the intermediate landing if there is a continuous handrail opposite the side access;
- e. no doors swing across landings;
- f. it has flights whose surface width between enclosing walls, strings or upstands is not less than 1.2m;
- g. there are no single steps;
- h. the rise of a flight between landings contains no more than 12 risers for a going of less than 350mm and no more than 18 risers for a going of 350mm or greater (see Diagram 5);
- i. all nosings are made apparent by means of a permanently contrasting material 55mm wide on both the tread and the riser;
- j. the projection of a step nosing over the tread below is avoided but, if necessary, not more than 25mm (see Diagram 6);
- k. the rise and going of each step is consistent throughout a flight;

- l. the rise of each step is between 150mm and 170mm, except adjacent to existing buildings where, due to dimensional constraints, the case for a different rise is agreed with Building Control.
- m. the going of each step is between 280mm and 425mm;
- n. rises are not open;
- o. there is a continuous handrail on each side of a flight and landings;
- p. additional handrails divide the flight into channels not less than 1.2m wide and not more than 1.8m wide where the overall unobstructed width is more than 1.8m.

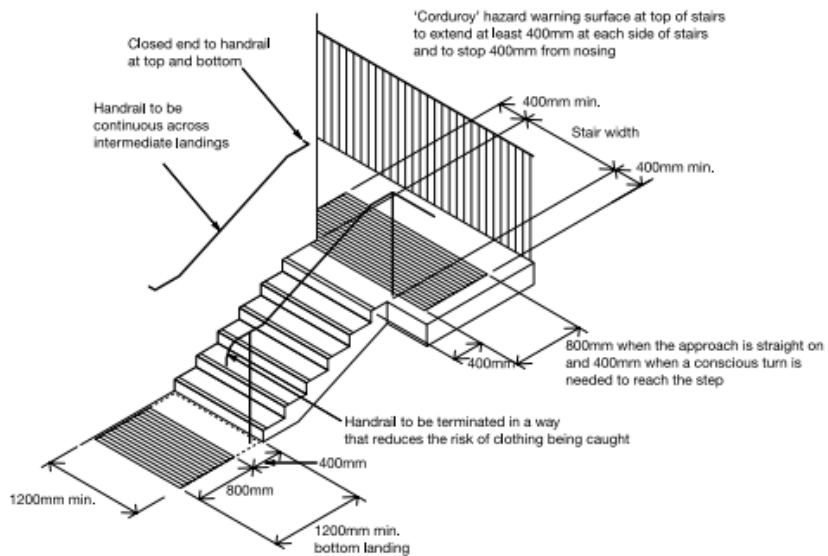
**Note:** In respect of 1.33(l) and (m), for school buildings, the preferred dimensions are a rise of 150mm, and a going of 280mm.

**Diagram 4 Stepped access – key dimensions and use of hazard warning surface**

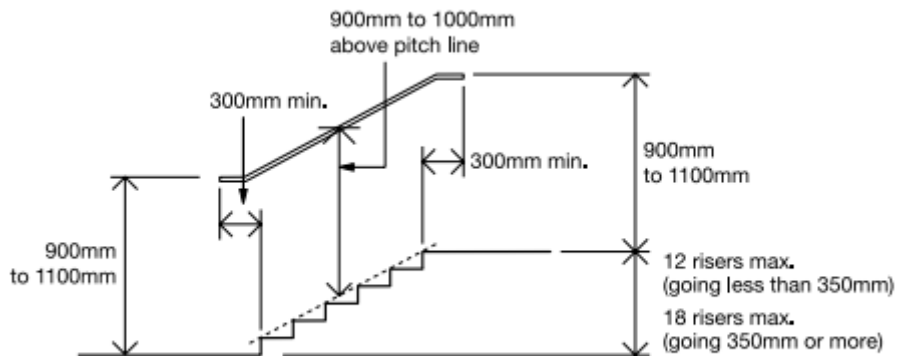


'Corduroy' hazard warning surface (with 8mm ribs)

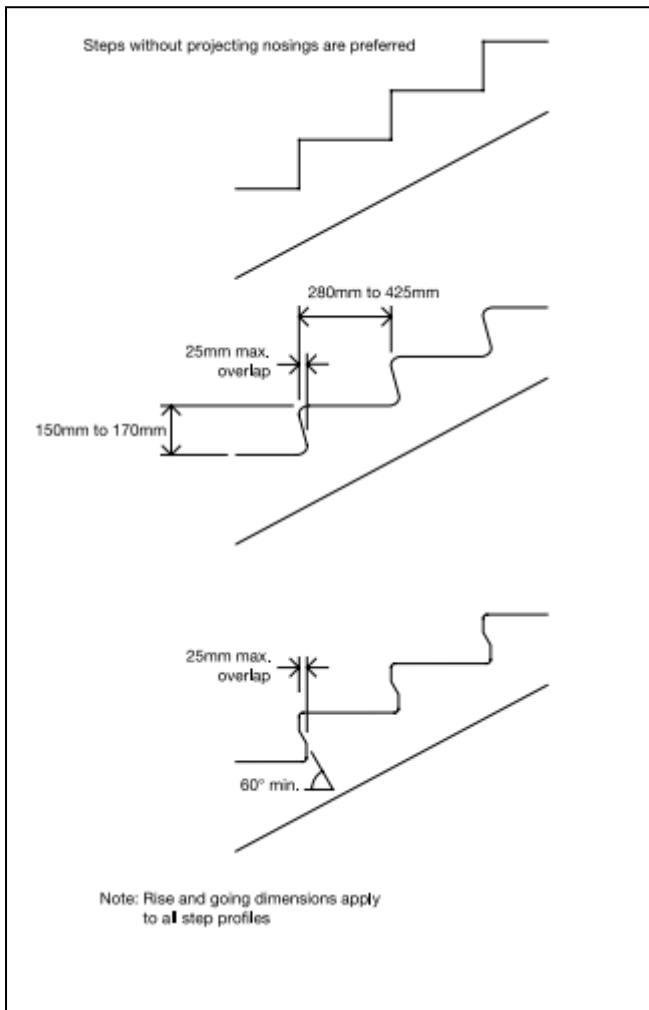
Note: Full details of tactile paving are in "Guidance on the use of Tactile Paving Surfaces."



**Diagram 5 External steps and stairs – key dimensions**



**Diagram 6 Examples of acceptable step profiles and key dimensions for external stairs**



## Handrails to external stepped and ramped access

### Design considerations

**1.34** People who have physical difficulty in negotiating changes of level need the help of a handrail that can be gripped easily, is comfortable to touch and, preferably, provides good forearm support.

**1.35** Handrails should be spaced away from the wall and rigidly supported in a way that avoids impeding finger grip.

**1.36** Handrails should be set at heights that are convenient for all users of the building and should extend safely beyond the top and bottom of a flight of steps, or a ramp, to give both stability and warning of the presence of a change in level. Consideration should be given to the provision of a second handrail on stairs in a wide range of building types, and particularly in schools, for use by children and people of short stature.

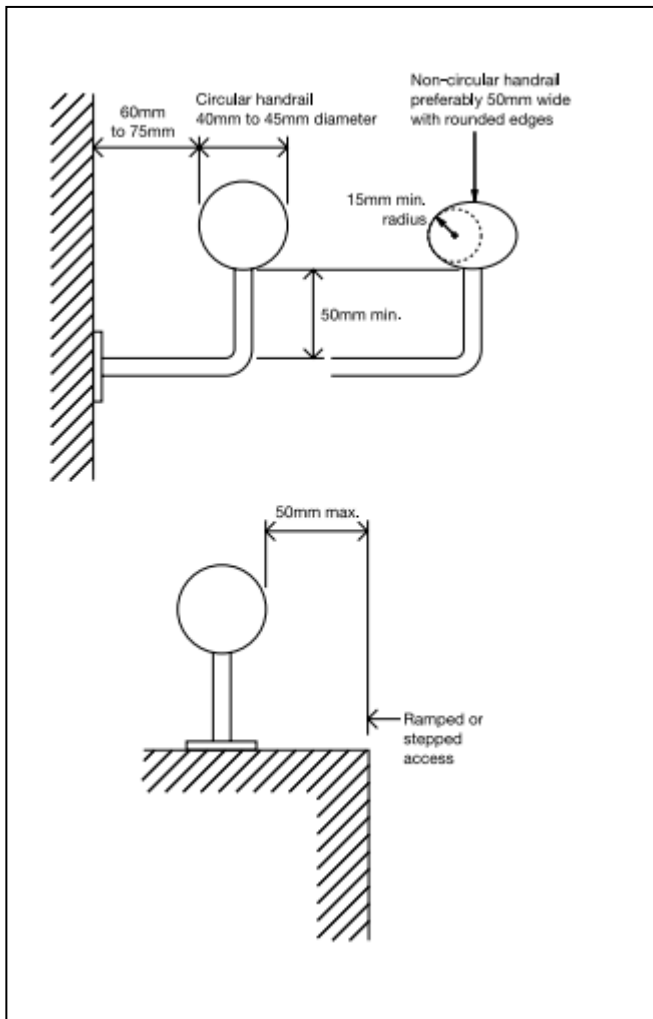
### Provisions

**1.37** Handrails to external ramped and stepped access will satisfy Requirement R1 or R2 if:

- a. the vertical height to the top of the upper handrail from the pitch line of the surface of a ramp, or a flight of steps, is between 900mm and 1000mm, and from the surface of a landing is between 900 and 1100mm (see Diagram 5);
- b. where there is full height structural guarding, the vertical height to the top of a second lower handrail from the pitch line of the surface of a ramp, or a flight of steps, is 600mm, where provided;

- c. it is continuous across the flights and landings of ramped or stepped access;
- d. it extends at least 300mm horizontally beyond the top and bottom of a ramped access, or the top and bottom nosing of a flight or flights of steps, while not projecting into an access route;
- e. it contrasts visually with the background against which it is seen, without being highly reflective;
- f. its surface is slip resistant and not cold to the touch; in areas where resistance to vandalism or low maintenance are key factors, use of metals with relatively low thermal conductivity may be appropriate.
- g. it terminates in a way that reduces the risk of clothing being caught;
- h. its profile is either circular with a diameter of between 40 and 45mm, or oval (non-circular) 50mm wide and 39mm deep having rounded edges with a radius a minimum of 15mm (see Diagram 7);
- i. it protrudes no more than 100mm into the surface width of the ramped or stepped access where this would impinge on the stair width requirement of Part E.
- j. there is a clearance of between 60 and 75mm between the handrail and any adjacent wall surface;
- k. there is a clearance of at least 50mm between a cranked support and the underside of the handrail;
- l. its inner face is located no more than 50mm beyond the surface width of the ramped or stepped access.

**Diagram 7 Handrail design**



## Hazards on access routes

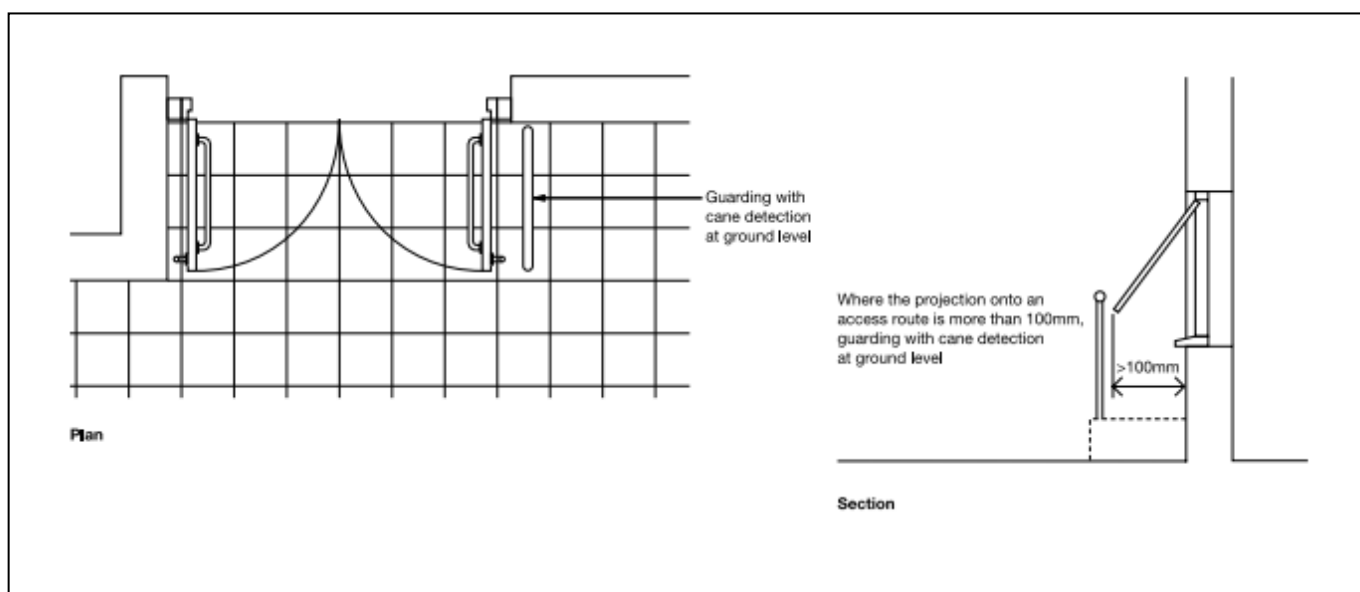
### Design considerations

**1.38** Features of a building that occasionally obstruct an access route, particularly if they are partially transparent and therefore indistinct, or cause a danger overhead, should not present a hazard to building users.

**1.39** Requirement R1 or R2 will be satisfied if:

- a. where there is a projection of more than 100mm, during normal use, onto an access route, windows and doors (excluding fire escape doors) that swing outwards an access route, or other projecting features, are protected by guarding, which incorporates a kerb or other solid barrier that can be detected using a cane at ground level (see Diagram 8);
- b. areas below stairs or ramps where the soffit is less than 2.1m above ground level are protected by guarding and low level cane detection, or a permanent barrier giving the same degree of protection.

**Diagram 8** Avoiding hazards on access routes



---

## Section 2: Access into buildings other than dwellings

---

### Objectives

**2.1** The aim for all new buildings is for the principal entrance or entrances and any main staff entrance, and any lobbies, to be accessible.

**2.2** Where it is not possible, e.g. in an existing building, for the principal or main staff entrance or entrances to be accessible, an alternative entrance should be provided.

**2.3** It is important to reduce the risks to people when entering the building.

### Accessible entrance

**2.4** Steeply sloping or restricted sites sometimes make it impossible for the principal or main staff entrance to be accessible, in which case an alternative accessible entrance may be necessary.

**2.5** Accessible entrances should be clearly sign-posted and easily recognizable. Any structural elements, for example supports for a canopy, are useful in identifying the entrance, but should not present a hazard.

**2.6** The route from the exterior across the threshold should provide weather protection, and not present a barrier for wheelchair users or a trip hazard for other people. A level threshold is preferred, especially for doors in frequent use.

**Note:** Guidance on sign-posting is given in BS 8300, Inclusive mobility and the Sign design guide.

### Provisions

**2.7** Accessible entrances will satisfy Requirement R1 or R2 if:

- a. they are clearly sign-posted, incorporating the International Symbol of Access, from the edge of the site and from the principal entrance (if this is not accessible);
- b. they are easily identified among the other elements of the building and the immediate environment e.g. by lighting and/or visual contrast;
- c. any structural supports at the entrance do not present a hazard for visually impaired people;
- d. there is a level landing at least 1500 x 1500mm, clear of any door swings, immediately in front of the entrance and of material that does not impede the movement of wheelchairs;
- e. the threshold is level or, if a raised threshold is unavoidable, it has a total height of not more than 15mm, a minimum number of upstands and slopes, with any upstands higher than 5mm chamfered or rounded;
- f. any door entry systems are accessible to deaf and hard of hearing people, and people who cannot speak;
- g. weather protection is provided at manual non-powered entrance doors;
- h. internal floor surfaces adjacent to the threshold are of materials that do not impede the movement of wheelchairs, e.g. not coir matting, and changes in floor materials do not create a potential trip hazard;
- i. where mat wells are provided, the surface of the mat is level with the surface of the adjacent floor finish;



- j. where provided as an alternative accessible entrance, an accessible internal route is provided to the spaces served by the principal or main staff entrances.

## Doors to accessible entrances

### Design considerations

**2.8** Doors to the principal, or alternative accessible, entrance should be accessible to all, particularly wheelchair users and people with limited physical dexterity. Entrance doors may be manually operated without powered assistance, or power operated under manual or automatic control. Entrance doors should be capable of being held closed when not in use.

**2.9** A non-powered manually operated entrance door, fitted with a self-closing device capable of closing the door against wind forces and the resistance of draught seals is unlikely to be openable by many people, particularly those who are wheelchair users or who have limited strength.

**2.10** A powered door opening and closing system either manually controlled or automatically operated by sensors, is the most satisfactory solution for most people. An automatic sliding door arrangement is particularly beneficial as it avoids the risks associated with automatic swing doors and its use can make it possible to reduce the length of any entrance lobby.

**2.11** Once open, all doors to accessible entrances should be wide enough to allow unrestricted passage for a variety of users, including wheelchair users, people carrying luggage, people with assistance dogs, and parents with pushchairs and small children. It should be noted that double buggies are wider than wheelchairs and that, where relevant to the building type, this should be borne in mind when determining an appropriate effective clear width for an entrance door. There may be circumstances in existing buildings where it

is not practicable or cost-effective to adopt the preferred clear widths for new buildings.

**2.12** People should be able to see other people approaching from the opposite direction, thereby allowing sufficient reaction time for both parties to avoid a collision. Exceptions may be acceptable for reasons of privacy or security

### Provisions

**2.13** Doors to accessible entrances will satisfy Requirement R1 or R2 if:

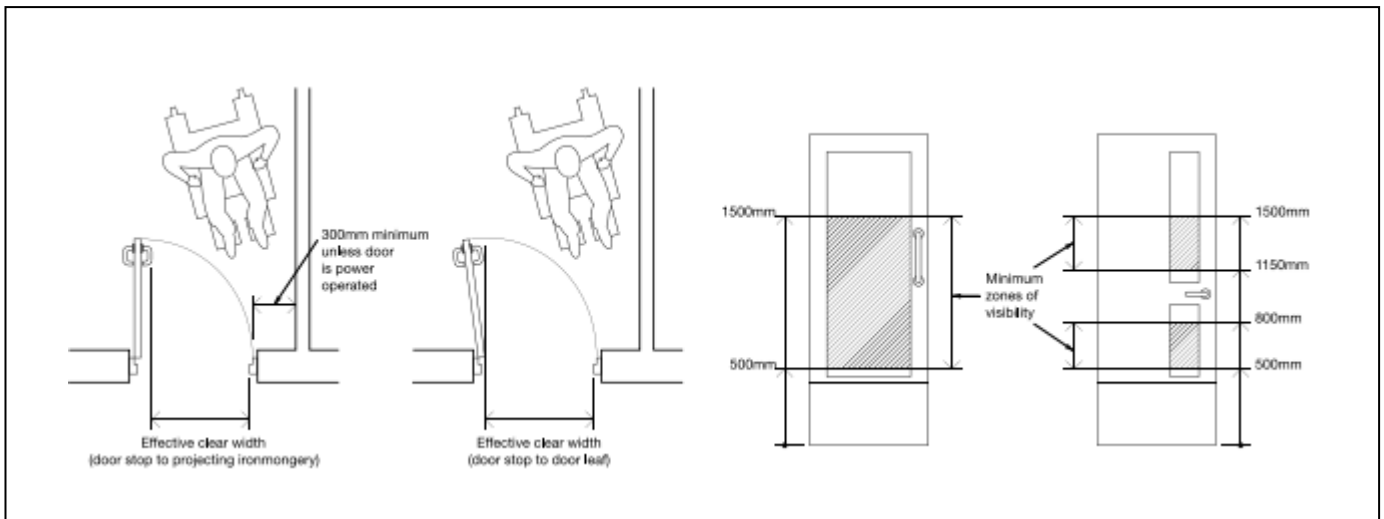
- a. where required to be self-closing, a power-operated door opening and closing system is used when through calculation and experience it appears that it will not be possible otherwise for a person to open the door using a force no greater than 30N at the leading edge from 0° (the door in the closed position) to 30° open, and not more than 22.5N at the leading edge from 30° to 60° of the opening circle;
- b. the effective clear width through a single leaf door, or one leaf of a double leaf door, is in accordance with Table 2, and the rules for measurement are in accordance with Diagram 9;
- c. unless it can be argued otherwise, e.g. for reasons of security, door leaves and side panels wider than 450mm have vision panels towards the leading edge of the door whose vertical dimensions include at least the minimum zone, or zones, of visibility between 500mm and 1500mm from the floor, if necessary interrupted between 800mm and 1150 mm above the floor, e.g. to accommodate an intermediate horizontal rail (see Diagram 9).

**Table 2 Minimum effective clear width of doors**

Direction and width of approach	New buildings (mm)	Existing buildings (mm)
Straight-on (without a turn or oblique approach)	800	750
At right angles to an access route At least 1500mm wide	800	750
At right angles to an access route At least 1200mm wide	825	775
External doors to buildings used By the general public	1000	775

**Note:**  
The effective clear width is the width of the opening measured at right angles to the wall in which the door is situated from the outside of the doorstop on the door closing side to any obstruction on the hinge side, whether this be projecting door opening furniture, a weather board, the door or the door stop (see Diagram 9). For specific guidance on the effective clear widths of doors in sports accommodation, refer to "Access for Disabled People".

**Diagram 9 Effective clear width and visibility requirements of doors**



## Manually operated non-powered entrance doors

### Design considerations

**2.14** Self closing devices on manually operated non-powered swing doors disadvantage many people who have limited upper body strength, are pushing prams or are carrying heavy objects.

**2.15** A space alongside the leading edge of a door should be provided to enable a wheelchair user to reach and grip the door handle, then open the door without releasing hold on the handle and without the footrest colliding with the return wall.

**2.16** Door furniture on manually operated non-powered doors should be easy to operate by people with limited manual dexterity, and be readily apparent against the background of the door.

**2.17** Manually operated non-powered entrance doors will satisfy Requirement R1 or R2 if:

- a. the opening force at the leading edge of the door is not more than 30N; at the leading edge from 0° (the door in the closed position) to 30° open, and not more than 22.5N at the leading edge from 30° to 60° of the opening cycle;
- b. there is an unobstructed space of at least 300mm on the pull side of the door between the leading edge of the door and any return wall, unless the door is a powered entrance door (see Diagram 9);
- c. where fitted with a latch, the door opening furniture can be operated with one hand using a closed fist, e.g. a lever handle;
- d. all door opening furniture contrasts visually with the surface of the door and is not cold to the touch.

## Powered entrance doors

### Design considerations

**2.18** Activation (e.g. motion sensors and push buttons), safety features and the time-lapse allowed for entry and exit through powered door systems should be carefully considered to suit the needs of people who cannot react quickly.

**2.19** Manual controls for powered entrance doors should be clearly distinguishable against the background and not located so that a person, having used the control, needs to move to avoid contact with the door as it opens.

**2.20** Revolving doors are not considered accessible. They create particular difficulties, and risk of injury, for people with assistance dogs, people with visual impairment or mobility problems and for parents with children and/or pushchairs. If a revolving door is used, an entrance door complying with 2.17 or 2.21 should be provided immediately adjacent to it and signed to show that it is accessible.

### Provisions

**2.21** Powered entrance doors will satisfy Requirement R1 or R2 if:

- a. they have a sliding, swinging or folding action controlled:
  - manually by push pad, card swipe, coded entry or remote control, or
  - automatically by a motion sensor or other proximity sensor, e.g. a contact mat;
- b. when installed, automatic sensors are set so that automatically operated doors open early enough, and stay entry and exit;
- c. when they are swing doors that open towards the people approaching the doors, visual and audible warnings are provided to warn people of their automatic operation when both opening and shutting;

- d. they incorporate a safety stop that is activated if the doors begin to close when a person is passing through;
- e. they revert to manual control or fail safe in the open position in the event of a power failure;
- f. when open, they do not project into any adjacent access route;
- g. any manual controls for powered door systems are located between 750mm and 1000mm above floor level, operable with a closed fist and, when on the opening side of the door, are set back 1400mm from the leading edge of the door when fully open and contrast visually (*Where illuminance on surfaces is greater than 200 lux, a difference in light reflectance value should be a minimum of 20 points. Where door opening furniture projects beyond the face of the door or otherwise creates enhances differentiation and shade, a minimum difference in light reflectance value of 15 points is considered adequate. See BS 8300, BS 4800 for further information. Guidance can also be obtained from Colour, Contrast and Perception - Design guidance for internal built environments*).
- h. with the background against which they are seen.

### Design considerations

**2.22** People with visual impairment should be in doubt as to the location of glass entrance doors, especially when they are within glazed screen. The choice of a different style of manifestation for the door and the glazed screen can help to differentiate between them.

**2.23** The presence of the door should be apparent not only when it is shut but also when it is open. Where it can be held open, steps should be taken to avoid people being harmed by walking into the door.

### Provisions

**2.24** Glass entrance doors and glazed screens will satisfy Requirement R1 or R2 if:

- a. they are clearly defined with manifestation on the glass at two levels, 850 to 1000mm and 1400 to 1600mm above the floor, contrasting visually with the background seen through the glass (both from inside and outside) in all lighting conditions;
- b. manifestation takes the form of a logo or sign at least 150mm high (repeated if on a glazed screen), or a decorative feature such as broken lines or continuous bands, at least 50mm high;
- c. glazed entrance doors, where adjacent to, or forming part of, a glazed screen, are clearly differentiated from it by the provision of a high-contrast strip at the top and on both sides;
- d. glass entrance doors, where capable of being held open, are protected by guarding to prevent the leading edge constituting a hazard.

## Entrance lobbies

### Design considerations

**2.25** There are a number of reasons for providing a lobby:

- to limit air infiltration
- to maintain comfort by controlling draughts
- to increase security
- to provide transitional lighting.

**2.26** The provision of a lobby may make it possible for an external door to have a self-closing device with a lower power size rating than might otherwise be the case. However, even in these circumstances, it may not be possible for the entrance door to meet the opening force criterion of 30N at the leading edge from 0° (the door in the closed position) to 30° open, and not more than

22.5N at the leading edge from 30° to 60° of the opening cycle.

**2.27** The lobby should be large enough and of a shape to allow a wheelchair user or a person pushing a pram to move clear of one door before opening the second door. The lobby should also be capable of accommodating a companion helping a wheelchair user to open doors and guide the wheelchair through. The minimum length of the lobby is related to the chosen door size, the swing of each door, the projection of the door into the lobby and the size of an occupied wheelchair with a companion pushing. Where both doors of a lobby are automatic sliding doors, the length can be reduced as no door swings are involved, nor is space required for manual operation. Similarly, if 'reduced swing' door sets are used, the length can be reduced because the projection of the door into the lobby is reduced.

**2.28** The aim should be to reduce potential hazards from local obstructions within the lobby and minimize distracting reflections from glazing. It is also desirable if rainwater from shoes or the wheels of wheelchairs is not taken into the building where it becomes a potential slip hazard, e.g. by the use of cleaning mats.

### Provisions

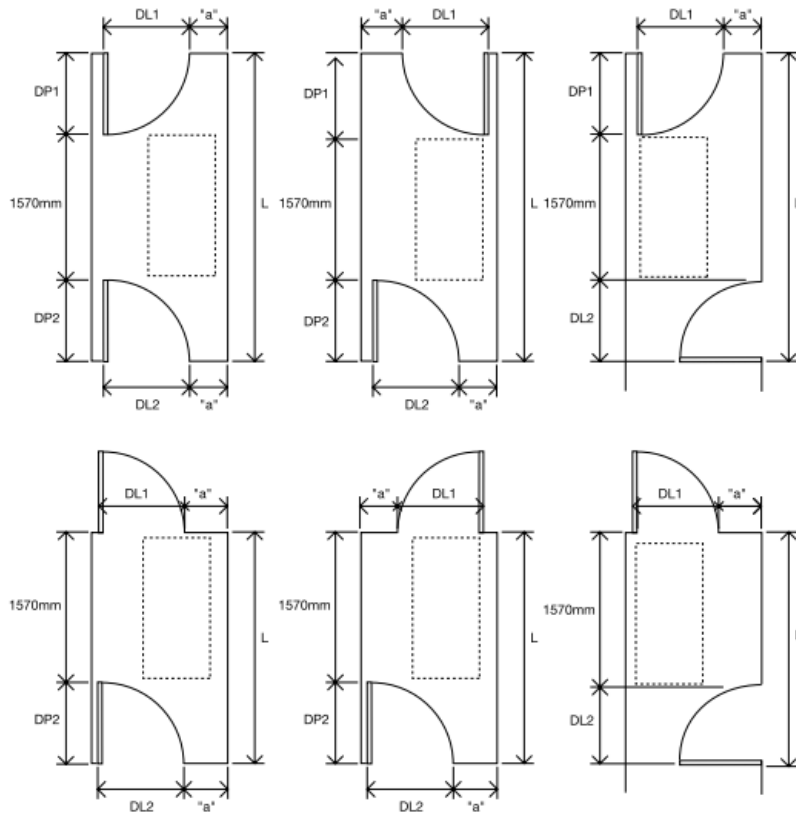
**2.29** Entrance lobbies will satisfy Requirement R1 of R2 if:

- a. their length with single swing doors is in accordance with Diagram 10;
- b. their length with double swing doors is at least  $(DP1 + DP2 + 1570\text{mm})$ ;
- c. their width (excluding any projections into the space) is at least 1200mm (or DL1 of DL2) + 300mm) whichever is the greater which single leaf doors are used, and at least 1800mm when double leaf doors are used;
- d. glazing within the lobby does not create distracting reflections;
- e. floor surface materials within the lobby do not impede the movement of wheelchairs, e.g. not

coir matting, and changes in floor materials do not create a potential trip hazard;

- f. the floor surface helps to remove rainwater from shoes and wheelchairs;
- g. where mat wells are provided, the surface of the mat is level with the surface of the adjacent floor finish;
- h. any columns, ducts and similar full height elements that project into the lobby by more than 100mm are protected by a visually contrasting guard rail.

## Diagram 10 Key dimensions for lobbies with single leaf doors



DL1 and DL2 = door leaf dimensions of the doors to the lobby  
 DP1 and DP2 = door projection into the lobby (normally door leaf size)  
 L = minimum length of lobby, or length up to door leaf for side entry lobby  
 'a' = at least 300mm wheelchair access space (can be increased to reduce L)  
 1570mm = length of occupied wheelchair with a companion pushing (or a large scooter)

NB: For every 100mm increase above 300mm in the dimension 'a' (which gives a greater overlap of the wheelchair footprint over the door swing), there can be a corresponding reduction of 100mm in the dimension L, up to a maximum of 600mm reduction.

---

## Section 3: Horizontal and vertical circulation in buildings other than dwellings

---

### Objective

**3.1** The objective is for all people to travel vertically and horizontally within buildings conveniently and without discomfort in order to make use of all relevant facilities. This objective relates in the main, but not exclusively, to the provision of sufficient space for wheelchair manoeuvre and design features that make it possible for people to travel independently within buildings

### Entrance hall and reception area

#### Design considerations

**3.2** As the entrance hall is the first point of contact with a building's activities and resources, the reception area in particular should not only be easily accessible but also convenient to use.

**3.3** Where a service building has a reception or sales counter, there should be convenient access to it and part of it should be at a level suitable for a wheelchair user or a seated person. Any lower section should also be wheelchair-accessible on the reception side.

**3.4** Designers should also be aware that glazed screens in front of the reception point, or light sources or reflective wall surfaces, such as glazed screens, located behind the reception point, could compromise the ability of a person with a hearing impairment to lip read or follow sign language.

**3.5** It should be possible for information about the building to be easily obtained from a reception point or gathered from notice boards and signs.

**Note:** Guidance on aids to communication is available in BS 8300, and on the use of signs in the Sign design guide.

### Provisions

**3.6** An entrance hall and reception area will satisfy Requirement R1 or R2 if:

- a. any reception point is located away from the principal entrance (while still providing a view of it) where there is a risk that external noise will be a problem;
- b. any reception point is easily identifiable from the entrance doors or lobby, and the approach to it is direct and free from obstructions;
- c. the design of the approach to any reception point allows space for wheelchair users to gain access to the reception point;
- d. the clear manoeuvring space in front of any reception desk or counter is 1200mm deep and 1800mm wide if there is a knee recess at least 500mm deep, or 1400mm deep and 2200mm wide if there is no knee recess;
- e. any reception desk or counter is designed to accommodate both standing and seated visitors such that at least one section of the counter is at least 1500mm wide, with its surface no higher than 760mm, and a knee recess, not less than 700mm, above floor level;
- f. any reception point is provided with a hearing enhancement system,, e.g. an induction loop;

- g. the floor surface is slip resistant.

## Internal doors

### Design considerations

**3.7** Since doors are potential barriers, their use should be avoided whenever appropriate. If doors are required, the use of self-closing devices should be minimized (particularly in parts of buildings used by the general public) since, as described in 2.14, they disadvantage many people who have limited upper body strength, are pushing prams or are carrying heavy objects. Where closing devices are needed for fire control, electrically powered hold-open devices or swing-free closing devices should be used as appropriate. These are devices whose claim mechanism is only activated in case of emergency. Low energy powered door systems may be used in locations not subject to frequent use or heavy traffic as the opening and closing action is relatively slow.

**3.8** The presence of doors, whether open or closed, should be apparent to visually impaired people through the careful choice of colour and material for the door and its surroundings. For example, when a door is open, people with impaired sight should be able to identify the door opening within the wall, as well as the leading edge of the door.

**3.9** Other design considerations for internal doors are as set out in 2.14 to 2.16 under 'Manually operated non-powered entrance doors' and should be referred to for guidance.

Note: Guidance is available in BS 8300 on:

- electrically powered hold-open devices
- swing-free systems
- low energy powered door systems.

**3.10** Internal doors will satisfy Requirement R1 or R2 if:

- a. where needing to be opened manually, the opening force at the leading edge of the door is not more than 30N at the leading edge from 0° (the door in the closed position) to 30° open, and not more than 22.5N at the leading edge from 30° to 60° of the opening cycle;
- b. the effective clear width through a single leaf door, or one leaf of a double leaf door, is in accordance with Table 2 and Diagram 9;
- c. there is an unobstructed space of at least 300mm on the pull side of the door between the leading edge of the door and any return wall, unless the door has power-controlled opening or it provides access to a standard hotel bedroom;
- d. there is an unobstructed space of at least 300mm on the pull side of the door between the leading edge of the door and any return wall, unless the door has power-controlled opening or it provides access to a standard hotel bedroom;
- e. where fitted with a latch, the door opening furniture can be opened with one hand using a closed fist, e.g. a lever handle;
- f. all door opening furniture contrasts visually with the surface of the door;
- g. the door frames contrast visually with the surrounding wall;
- h. where appropriate in door leaves or side panels wider than 450mm, vision panels towards the leading edge of the door have vertical dimensions which include at least minimum zone, or zones, of visibility between 500mm and 1500mm from the floor, if necessary interrupted between 800mm and 1150mm above the floor, e.g. to accommodate an intermediate horizontal rail.
- i. when of glass, they are clearly defined with manifestation on the glass at two levels,



850 to 1000mm and 1400 to 1600mm, contrasting visually with the background seen through the glass in all lighting conditions (see 2.24(b) for details of manifestation);

- j. when of glass of fully glazed, they are clearly differentiated from any adjacent glazed wall or partition by the provision of a high-contrast strip at the top and on both sides;
- k. fire doors, particularly those in corridors, are held open with an electro-magnetic device, but self-close when;
  - activated by smoke detectors linked to the door individually, or to a main fire/smoke alarm system;
  - the power supply fails;
  - activated by a hand-operated switch;
- l. fire doors, particularly to individual rooms, are fitted with swing-free devices that close when activated by smoke detectors or the building's fire alarm system, or when the power supply fails;
- m. any low energy powered swing door system is capable of being operated in manual mode, in powered mode or in power-assisted mode.

## Corridors and passageways

### Design considerations

**3.11** Corridors and passageways should be wide enough to allow people with buggies, people carrying cases or people on crutches to pass others on the access route. Wheelchair users should also have access to adjacent rooms and spaces, be able to pass other people and, where necessary, turn through 180°. Corridors narrower than indicated in this guidance, or localized narrowing (e.g. at archways), might be reasonable in some

locations, such as in existing buildings or in some extensions.

**3.12** In order to help people with visual impairment to appreciate the size of a space they have entered, or to find their way around, there should be a visual contrast between the wall and the ceiling, and between the wall and the floor. Such attention to surface finishes should be coupled with good natural and artificial lighting design.

**3.13** Good acoustic design should be employed to achieve an acoustic environment that is neither too reverberant nor too absorbent so that announcements and conversations can be heard clearly.

### Provisions

**3.14** Corridors and passageways will satisfy Requirement R1 or R2 if:

- a. Elements such as columns, radiators and fire hoses do not project into the corridor, or where this is unavoidable, a means of directing people around them, such as a visually contrasting guard rail, is provided;
- b. they have an unobstructed width (excluding any projections into the space) along their length of at least 1200mm;
- c. where they have an unobstructed width of less than 1800mm, they have passing places at least 1800mm long and with an unobstructed width of at least 1800mm at reasonable intervals, e.g. at corridor junctions, to allow wheelchair users to pass each other;
- d. the floor is level or predominantly level (with a gradient no steeper than 1:60), with any section with a gradient of 1:20 or steeper designed as an internet ramp and in accordance with Table 1 and Diagram 3;
- e. where a section of the floor has a gradient, in the direction of travel, steeper than 1:60, but less steep than 1:20, it rises no more

than 500mm without a level rest area at least 1500mm long (with a gradient no steeper than 1:60);

- f. any sloping section extends the full width of the corridor or, if not, the exposed edge is clearly identified by visual contrast and, where necessary, protected by guarding;
- g. any door opening towards a corridor, which is a major access route or an escape route, should be recessed so that, when fully open, it does not project into the corridor space, except where the doors are to minor utility facilities, such as small store rooms and locked duct cupboards;
- h. any door from a unisex wheelchair-accessible toilet projects when open into a corridor that is not a major access route or an escape route, provided the corridor is at least 1800mm wide at that point;
- i. on a major access route or an escape route, the wider leaf of a series of double doors with leaves of unequal width is on the same side of the corridor throughout the length of the corridor;
- j. floor surface finishes with patterns that could be mistaken for steps or changes of level are avoided;
- k. floor finishes are slip resistant;
- l. any glazed screens alongside a corridor are clearly defined with manifestation on the glass at two levels, 850 to 1000mm and 1400 to 1600mm, contrasting visually with the background seen through the glass in all lighting conditions (see 2.24(b) for details of manifestation).

**Note:** In respect of 3.14(b) for school buildings, the preferred corridor width dimension is 2700mm where there are lockers within the corridor.

## Internal lobbies

### Design considerations

**3.15** An internal lobby should allow a wheelchair user with or without a companion, or a person pushing a pram or buggy to move clear of one door before attempting to open the second door, as indicated in 2.27, under 'External lobbies'.

**3.16** Internal lobbies will satisfy Requirement R1 or R2 if:

- a. their length with single swing doors is in accordance with Diagram 10;
- b. their length with double swing doors is at least (DP1 + DP2 + 1570mm);
- c. their width (excluding any projections into the space) is at least 1200mm (or DL1 or DL2) + 300mm whichever is the greater when single leaf doors are used, and at least 1800mm when double leaf doors are used;
- d. glazing within the lobby does not create distracting reflections;
- e. any junctions of floor surface materials at the entrance to the lobby area do not create a potential trip hazard;
- f. any columns, ducts and similar full height elements that project into the lobby by more than 100mm are protected by a visually contrasting guard rail.

### Vertical circulation within the building

#### Design considerations

**3.17** A Passenger lift is the most suitable means of vertical access and should be provided wherever possible. However, given

the space constraints in some buildings, it may not be possible to install the type and size of passenger lift that would be suitable for use by all, and other options may need to be considered to provide for users with mobility impairments.

**3.18** Signs indicating the location of a lifting device accessible by mobility-impaired people should be clearly visible from the building entrance. Additionally, a sign identifying the floor reached should be provided on each landing in a location that can be easily seen from the lifting device and is designed so that it contrasts visually with its surrounding.

**3.19** Whatever lifting device is chosen, internal stairs should always be provided as an alternative means of vertical access, and designed to suit ambulant disabled people and those with impaired sight.

**3.20** A ramp may also be provided on an internal circulation route to a suitable lifting device, if a change of level is unavoidable.

## Provision of lifting devices

### Design considerations

**3.21** For all buildings, a passenger lift is the most suitable form of access for people moving from one storey to another.

**3.22** For existing buildings, and in exceptional circumstances for new developments with particular constraints (e.g. a listed building or an infill site in a historic town centre), where a passenger lift cannot be accommodated, a vertical lifting platform (platform lift), although not equivalent to a passenger lift, may be considered an alternative option to provide access for persons with impaired mobility.

**3.23** In exceptional circumstances in an existing building, a wheelchair platform stairlift may be considered, provided its installation does not conflict with requirements for means of escape.

## Provisions

**3.24** The provision of lifting devices will satisfy Requirement R1 or R2 if:

- a. new developments have a passenger lift serving all storeys;
- b. new developments, where due to site constraints a passenger lift cannot be accommodated to provide access to persons with impaired mobility, have a lifting platform, of a type designed for the vertical height to be travelled;
- c. existing buildings have a passenger lift serving all storeys or, if a passenger lift cannot reasonably be accommodated to provide access to persons with impaired mobility, they have a lifting platform, of a type designed for the vertical height to be travelled;
- d. existing buildings have a wheelchair platform stairlift serving an intermediate level or a single storey, only in exceptional circumstances.

## General requirements for lifting devices

### Design considerations

**3.25** In selecting the appropriate lifting device care should be taken to ensure it is fit for purpose. Relevant legislation includes the Management of Health and Safety at Work Regulations.

**3.26** The illumination in the passenger lift car, on the lifting platform or on the wheelchair platform stairlift should minimize glare, reflection, confusing shadows or pools of light and dark.

**3.27** All users including wheelchair users should be able to reach and use the controls that summon and direct the lifting device.

**Note:** Further guidance is available in BS 8300.  
**Provisions**

**3.28** The installation of lifting devices will satisfy Requirement R1 or R2 if:

- a. there is an unobstructed manoeuvring space of 1500mm x 1500mm, or a straight access route 900mm wide, in front of each lifting device;
- b. the landing call buttons are located between 900mm and 1100mm from the floor of the landing and at least 500mm from any return wall;
- c. the landing call button symbols, where provided, and lifting device control button symbols are raised to facilitate tactile reading;
- d. all call and control buttons contrast visually with the surrounding face plate, and the face plate similarly contrasts with the surface on which it is mounted;
- e. the floor of the lifting device should not be of a dark colour and should have frictional qualities similar to, or higher than, the floor of the landing;
- f. a handrail is provided on at least one wall of the lifting device with its top surface at 900mm (nominal) above the floor and located so that it does not obstruct the controls of the mirror;
- g. a suitable emergency communication system is fitted.

## Passenger lifts

### Design considerations

**3.29** A wheelchair user needs sufficient space and time to enter and leave a passenger lift, particularly when sharing it with other people. Lift sizes should therefore be chosen to suit the anticipated density of use of the building and the needs of disabled people. The minimum size lift car shown in the provisions below

accommodates a wheelchair user with an accompanying person. A larger size lift (2000mm wide by 1400mm deep) will accommodate any type of wheelchair together with several other passengers. It will also allow a wheelchair user of a person with a walking frame to turn through 180°.

**3.30** Lift door systems should be designed to allow adequate time for people and any assistance dogs, to enter or leave the lift without coming into contact with closing doors.

**3.31** People using or waiting for a lift need audible and visual information to tell them that a lift has arrived, which floor it has reached and where in a bank of lifts it is located.

**3.32** The use of visually and acoustically reflective wall surfaces can cause discomfort for people with visual and hearing impairment.

**3.33** Where planning allows, lift cars (used for access between two levels only) may be provided with opposing doors to allow a wheelchair user to leave without reversing out.

### Provisions

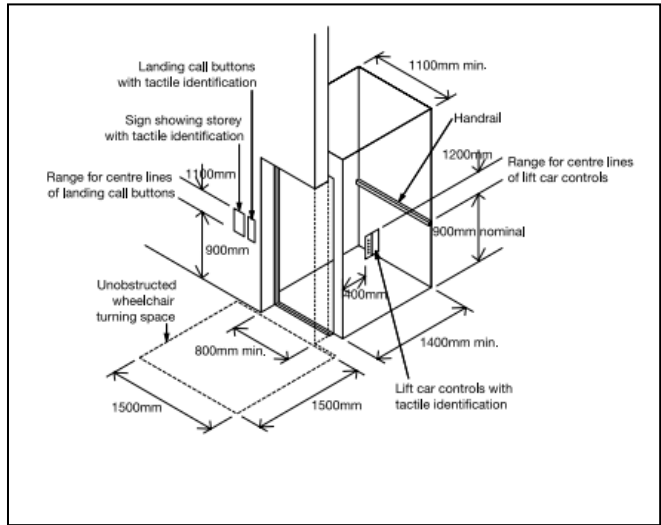
**3.34** Passenger lifts will satisfy Requirement R1 or R2 if:

- a. they conform to the relevant British Standards, EN 81 series of standards, in particular BS EN 81-70:2003 Safety Rules for the construction and installation of lifts. Particular applications for passenger and good passenger lifts, or, where necessary by product certification issued by a Notified Body);
- b. they are accessible from the remainder of the storey;
- c. the minimum dimensions of the lift cars are 1100mm wide and 1400mm deep (see Diagram 11);
- d. for lifts of a size that does not allow a wheelchair user to turn around within the lift

car, a mirror is provided in the lift car to enable a wheelchair user to see the space behind the wheelchair;

- e. power-operated horizontal sliding doors provide an effective clear width of at least 800mm (nominal);
- f. doors are fitted with timing devices and re-opening activators to allow adequate time for people and any assistance dogs to enter or leave;
- g. car controls are located between 900mm and 1200mm (preferably 1100mm) from the car floor and at least 400mm from any return wall.
- h. landing call buttons are located between 900mm and 1100mm from the floor of the landing and at least 500mm from any return wall;
- i. lift landing and car doors are distinguishable visually from the adjoining walls;
- j. audible and visual indication of lift arrival and location is provided in the lift car and the lift lobby;
- k. areas of glass are identifiable by people with impaired vision;
- l. where the lift is to be used to evacuate disabled people in an emergency, it conforms to the relevant recommendations of BS 5588-8.

**Diagram 11 Key dimensions associated with passenger lifts**



## Lifting platforms

### Design considerations

**3.35** A lifting platform should only be provided to transfer wheelchair users, people with impaired mobility and their companions vertically between levels or storeys.

**3.36** All users including wheelchair users should be able to reach and use the controls that summon and direct the lifting platform.

**3.37** People using or waiting for a lifting platform need audible and visual information to tell them that the platform has arrived, and which floor it has reached.

**3.38** Lifting platforms travel slowly between landings and may not be suitable for lone users with certain disabilities, e.g. those easily fatigued.

**3.39** Lifting platforms are operated by continuous pressure controls. In their simplest form these may be push buttons. However, another means of continuous pressure control may need to be considered to accommodate

the needs of users with varying degrees of manual dexterity.

**3.40** It is important when selecting a lifting platform that due care and attention is paid to its intended use particularly if located in an unsupervised environment. Where management control cannot be exercised, particular attention should be paid to the product's designed duty cycle.

**3.41** Where planning allows, lifting platforms may be provided with opposing doors when used for access between two levels only, to allow a wheelchair user to leave without reversing out. In some cases, it may be more convenient to provide a second door at 90° to the first, in which case a wider platform would be required.

**3.42** The use of visually and acoustically reflective wall surfaces should be minimized within the lifting platform to prevent discomfort for people with visual and hearing impairment.

## Provisions

**3.43** Lifting platforms will satisfy Requirement R1 or R2 if:

- a. they conform to the relevant British Standards, EN 81 series of standards or, where necessary, by product certification issued by a Notified Body. In the absence of relevant harmonised European Standards, products with a travel exceeding 3m must have a product certificate issued by a Notified Body;
- b. the vertical travel distance is:
  - i. not more than 2m, where there is no liftway enclosure and no floor penetration;
  - ii. more than 2m, where there is a liftway enclosure;

- c. the rated speed of the platform does not exceed 0.15m/s;
- d. lifting platforms controls are located between 800mm and 1100mm from the floor of the lifting platform and at least 400mm from any return wall;
- e. continuous pressure controls are provided;
- f. landing call buttons are located between 900mm and 1100mm from the floor of the landing and at least 500mm from any return wall;
- g. the minimum clear dimensions of the platform are:
  - i. 800mm wide and 1250mm deep, where the lifting platform is not enclosed and where provision is being made for an unaccompanied wheelchair user;
  - ii. 1100mm wide and 1400mm deep where two doors are located at 90° relative to each other and where the lifting platform is enclosed or where provision is being made for an accompanied wheelchair user;
  - ii. doors have an effective clear width of at least 900mm for an 1100mm wide and 1400mm deep lifting platform and at least 800mm in other cases;
- h. doors have an effective clear width of at least 900mm for an 1100mm wide and 1400mm deep lifting platform and at least 800mm in other cases;
- i. they are fitted with clear instructions for use;
- j. the lifting platform entrances are accessible from the remainder of the storey;
- k. doors are distinguishable visually from the adjoining walls;

- l. an audible and visual announcement of platform arrival and level reached is provided;
- m. areas of glass are identifiable by people with impaired vision.

- b. in a building with a single stairway, the required clear width of the flight of stairs and landings for means of escape is maintained when the wheelchair platform is in the parked position (see also Approved Document E).

## Wheelchair platform stairlifts

### Design considerations

**3.44** Wheelchair platform stairlifts are only intended for the transportation of wheelchair users and should only be considered for conversions and alterations where it is not practicable to install a conventional passenger lift or a lifting platform. Such stairlifts travel up the string of a stair. They should not be installed where their operation restricts the safe use of the stair by other people.

**3.45** A wheelchair platform stairlift allows a wheelchair user to travel independently up and down stairs while remaining seated in a wheelchair. A wheelchair platform stairlift may be more suitable for use in small areas with a unique function, e.g. a small library gallery, a staff rest room or a training room.

**3.46** Wheelchair platform stairlifts travel slowly between landings and may not be suitable for users with certain disabilities, e.g. those easily fatigued.

**3.47** Wheelchair platform stairlifts are operated by continuous pressure controls, commonly a joystick. However, another means of continuous pressure control may need to be considered to accommodate users with varying degrees of manual dexterity.

**3.48** Wheelchair platform stairlifts are only suitable where users can be instructed in their safe use and where management supervision can be ensured.

### Provisions

**3.49** Wheelchair platform stairlifts will satisfy Requirement R1 or R2 if:

- a. They conform with the relevant British Standards, EN81 series of standards or where necessary Notified Body approval;

- c. the rated speed of the platform does not exceed 0.15m/s;

- d. continuous pressure controls are provided;

- e. the minimum clear dimensions of the platform are 800mm wide and 1250mm deep;

- f. they are fitted with clear instructions for use;

- g. access with an effective clear width of at least 800mm is provided;

- h. controls are designed to prevent unauthorized use.

## Internal stairs

### Design considerations

**3.50** With the exception of the need for hazard warning surfaces on landings, other design considerations for internal stairs are as those for 'Stepped access (see 1.29 to 1.32). It is not reasonable to require a hazard warning surface at the head of internal stairs since there is no recognized warning surface for use internally which can be guaranteed not to constitute a trip hazard when used alongside flooring surfaces with different frictional resistance characteristics. However, designers should be aware of the potential risk of having a stair directly in line with an access route. For mobility-impaired people, a going of at least 300mm is preferred.

### Provisions

**3.51** Internal stairs will satisfy Requirement R1 or R2 if:

- a. they comply with provisions (a), (b), (e) to (g), and (i) to (k) and (n) to (p) of 1.33;
- b. a flight between landings normally contains no more than 12 risers, but exceptionally no more than 16 risers in small premises where the plan area is restricted (see Diagram 12);
- c. the rise of each step is between 150mm and 170mm, except in existing buildings here, due to dimensional constraints, the case for a different rise is argued in the Access Statement;
- d. the going of each step is at least 250mm;
- e. the area beneath a stair where the soffit is less than 2.1m above floor level is protected as described in 1.39(b).

**Note:** For school buildings, in respect of 3.51(c) and (d), the rise should not exceed 170mm, with a preferred going of 280mm. Also for schools refuges should be provided for all stairs where no other arrangement is in place (see Approved Document B, B1.xvi, and BS 5588-8 for details of refuges).

## Internal ramps

### Design considerations

**3.52** With the exception of issues relating specifically to the external environment, the design considerations for internal ramps are as those for 'Ramped access' (see 1.19 to 1.25). It is worth reiterating that ramps are not necessarily safe and convenient for ambulant disabled people. For example, some people who can walk but have restricted mobility find it more difficult to negotiate a ramp than a stair. Unless, therefore a ramp is short, has a

shallow gradient and the rise is no more than the minimum that can be provided by two risers, steps should be provided as well as a ramp.

**3.53** Internal ramps will satisfy Requirement R1 or R2 if:

- a. they comply with provisions (a) to (c), (e) to (j) and (l) to (m) for ramped access in 1.26;
- b. Where the change in level is 300mm or more, two or more clearly signposted steps are provided in addition to the ramp;
- c. Where the change in level is no greater than 300mm, a ramp is provided instead of a single step;
- d. all landings are level, subject to a maximum gradient of 1:60 along their length;
- e. the area beneath a ramp where the soffit is less than 2.1m above floor level is protected as described in 1.39(b).

## Handrails to internal steps, stairs and ramps

### Design considerations

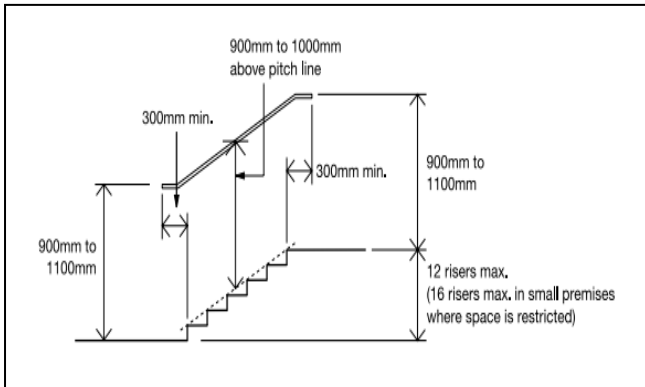
**3.54** The design considerations for handrails are as those for 'Handrails to external stepped and ramped access' in 1.34 to 1.36.

### Provisions

**3.55** Handrails to internal steps, stairs and ramps will satisfy Requirement R1 or R2 if they comply with all the provisions contained in 1.37.



**Diagram 12 Internal stairs – key dimensions**



---

## Section 4: Facilities in buildings other than dwellings

---

### Objectives

**4.1** The aim is for all people to have access to, and the use of, all the facilities provided within buildings. They should also be able to participate in the proceedings at lecture/conference facilities and at entertainment or leisure and social venues, not only as spectators but also as participants and/or staff.

**4.2** Where permanent or removable seating is provided as part of the design, allowance should be made for disabled people to have a choice of seating location at spectator events. It should also be possible for them to have a clear view of the activity taking place while not obstructing the view of others.

**4.3** In refreshment facilities, bars and counters (or sections of them) should be at a level suitable for wheelchair users. All floor areas, even when located at different levels, should be accessible.

**4.4** A proportion of the sleeping accommodation in hotels, motels and student accommodation should be designed for independent use by wheelchair users. The remainder should include facilities that make them suitable for people who do not use a wheelchair, but may have mobility, sensory, dexterity or learning difficulties.

### Audience and spectator facilities

#### Design considerations

**4.5** Audience and spectator facilities fall primarily into three categories:

- a. lecture/conference facilities.

- b. Entertainment facilities (e.g. theatres/cinemas).

- c. Sports facilities (e.g. stadia).

**Note:** The guidance here relates mainly to seating. For guidance on reception and sales counters, refer to 3.2 to 3.5.

#### *Audience facilities generally*

**4.6** Wheelchair users and those with mobility or sensory impairment may need to view or listen from a particular side, or sit in the front for lip reading or to read sign interpreters. They should be provided with spaces into which they can manoeuvre easily, and which offer them a clear view of an event, while ensuring they are not segregated into special areas. Wheelchair users, people who have difficulty in using seats with fixed arms and those with assistance dogs should also have the choice of sitting next to a conventionally seated person or a companion wheelchair user. Consideration should be given to providing an area next to certain seats for an assistance dogs to rest. By having some removable seating at the front and back of blocks of seats (possibly in complete rows), greater flexibility in location can be achieved and a greater number of wheelchair users than the minimum provision shown in Table 3 can be accommodated.

**4.7** Greater spacing between rows of seats at the rear of a block of seating, or at the end of rows, may provide extra legroom for people of large stature. With several seats removed, these locations may also be suitable for wheelchair users. It is desirable for seating to contrast visually with the surroundings.

**4.8** All users of facilities should be able to locate suitable seating and move safely and easily to and from the seating area and ancillary accommodation, such as lavatories, dining rooms and bedroom suites.

**4.9** People with hearing impairments should be able to participate fully in conferences, committee meetings and study groups. All people should be able to use presentation facilities. Consideration should be given to good sight lines and the design and location of lecture equipment (demonstration table, lectern projection screen) to ensure that patterned walls, poor interior lighting or very bright natural back-lighting does not have a detrimental effect on the ability of people to receive information from a sign language interpreter or a lip speaker (see 4.32 to 4.34).

*Entertainment, leisure and social facilities*

**4.10** In facilities for entertainment, e.g. theatres and cinemas, it is normal for seating to be more closely packed than in other types of auditoria. Care is needed in the design and location of wheelchair spaces so that all visitors can enjoy the atmosphere. Reference should also be made to Technical standard for places of entertainment.

*Sports facilities*

**4.11** For guidance on integrating the needs of disabled people into the design of spectator facilities, in particular the provision of, and access to, suitable spaces for wheelchair users in stadia, see Guide to safety at sports grounds, Accessible stadia: a good practice guide to the design of facilities to meet the needs of disabled spectators and other users and Access for disabled people.

**Provisions**

**4.12** Audience and spectator facilities will satisfy Requirement R1 if:

*For audience seating generally*

- a. the route to wheelchair spaces is accessible by wheelchair users;
- b. stepped access routes to audience seating are provided with fixed handrails (see 1.34 to 1.37 for details of handrails);
- c. the minimum number of permanent and removable spaces provided for wheelchair users is in accordance with Table 3;
- d. some wheelchair spaces (whether permanent or created by removing seats) are provided in pairs, with standard seating on at least one side (see Diagram 13);
- e. where more than two wheelchair spaces are provided, they are located to give a range of views of the event at each side, as well as the front and back of the seating area;
- f. the minimum clear space provided for access to wheelchair spaces is 900mm

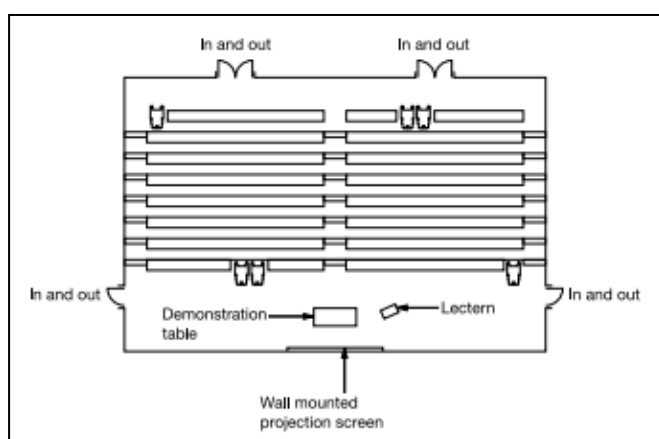
**Table 3 Provision of wheelchair space in audience seating**

Seating Capacity	Minimum provision of Spaces for wheelchairs	
	Permanent	Removable
Up to 600	1% of total seating Capacity (rounded up)	Remainder to make a total of 6
Over 600 But less than 10,000	1% of total seating Capacity (rounded up)	Additional provision, if desired
Note: For seating capacities of 10,000 or more, guidance is given in Accessible Stadia: a good practice guide to the design of facilities to meet the needs of disabled spectators and other users.		

- g. the clear space allowance for an occupied wheelchair in a parked position is 900mm wide by 1400mm deep;

- h. the floor of each wheelchair is horizontal;
- i. some seats are located so that an assistance dog can accompany its owner and rest in front of, or under, the seat;
- j. standard seats at the ends of rows and next to wheelchair spaces have detachable, or lift-up arms;

**Diagram 13 An example of wheelchair spaces in a lecture theatre**



***For seating on a stepped terraced floor***

- k. wheelchair spaces at the back of a stepped terraced floor are provided in accordance with Diagram 14 or 15, the arrangement in Diagram 15 being particularly suitable for entertainment buildings, such as theatres or cinemas.

***For lecture/conference facilities***

- l. where a podium or stage is provided, wheelchair users have access to it by means of ramps or lifting platform;
- m. a hearing enhancement system in accordance with 4.36 is provided for people with impaired hearing.

**Refreshment facilities**

**Design considerations**

**4.13** Refreshment facilities, such as restaurants and bars, should be designed so that they can be reached and used by all people independently or with companions. Staff areas should also be accessible.

**4.14** All public areas, including lavatory accommodation, public telephones and external terraces should be accessible. Where premises contain self-service and waiter service, all patrons should have access to both.

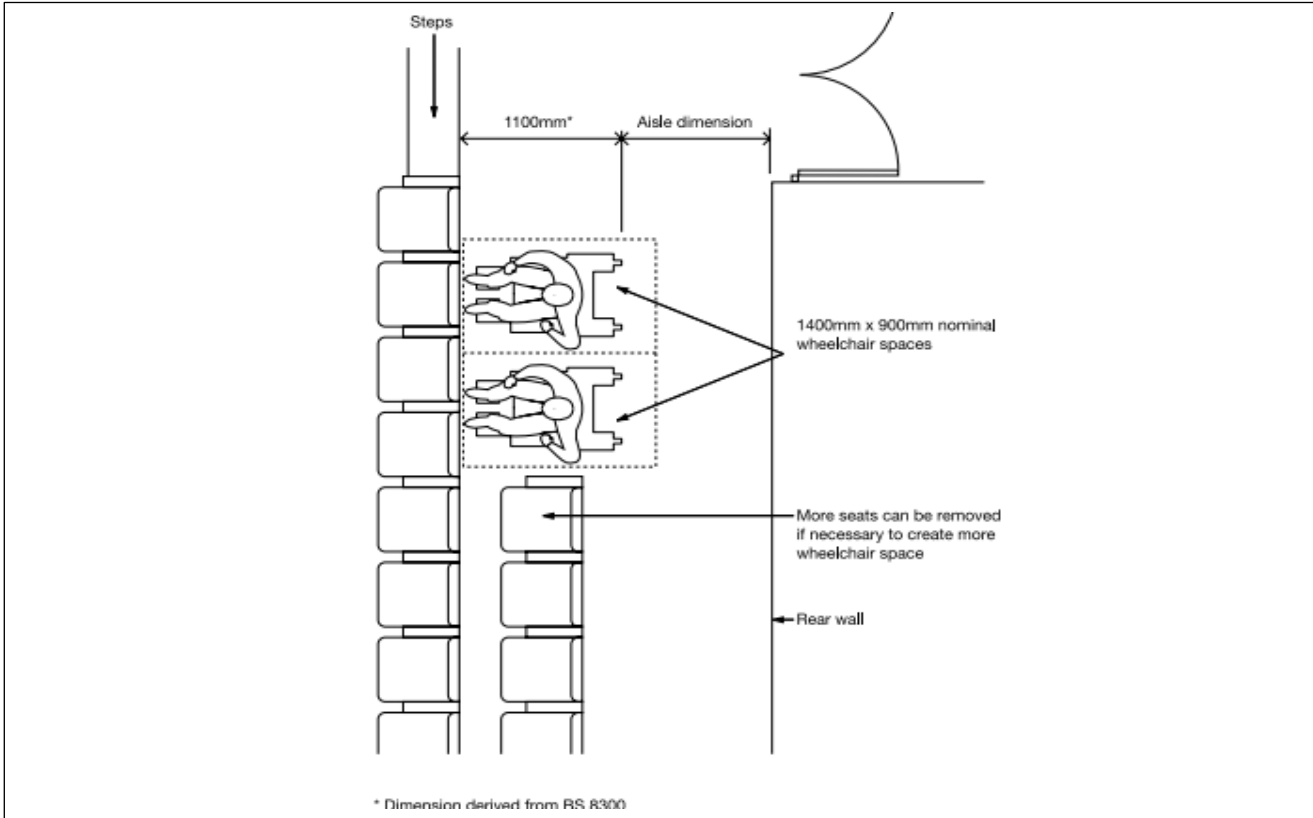
**4.15** In many refreshments facilities, changes in level are used to differentiate between different functions or to create a certain atmosphere through interior design. Changes of floor level are acceptable provided the different levels are accessible.

**Provisions**

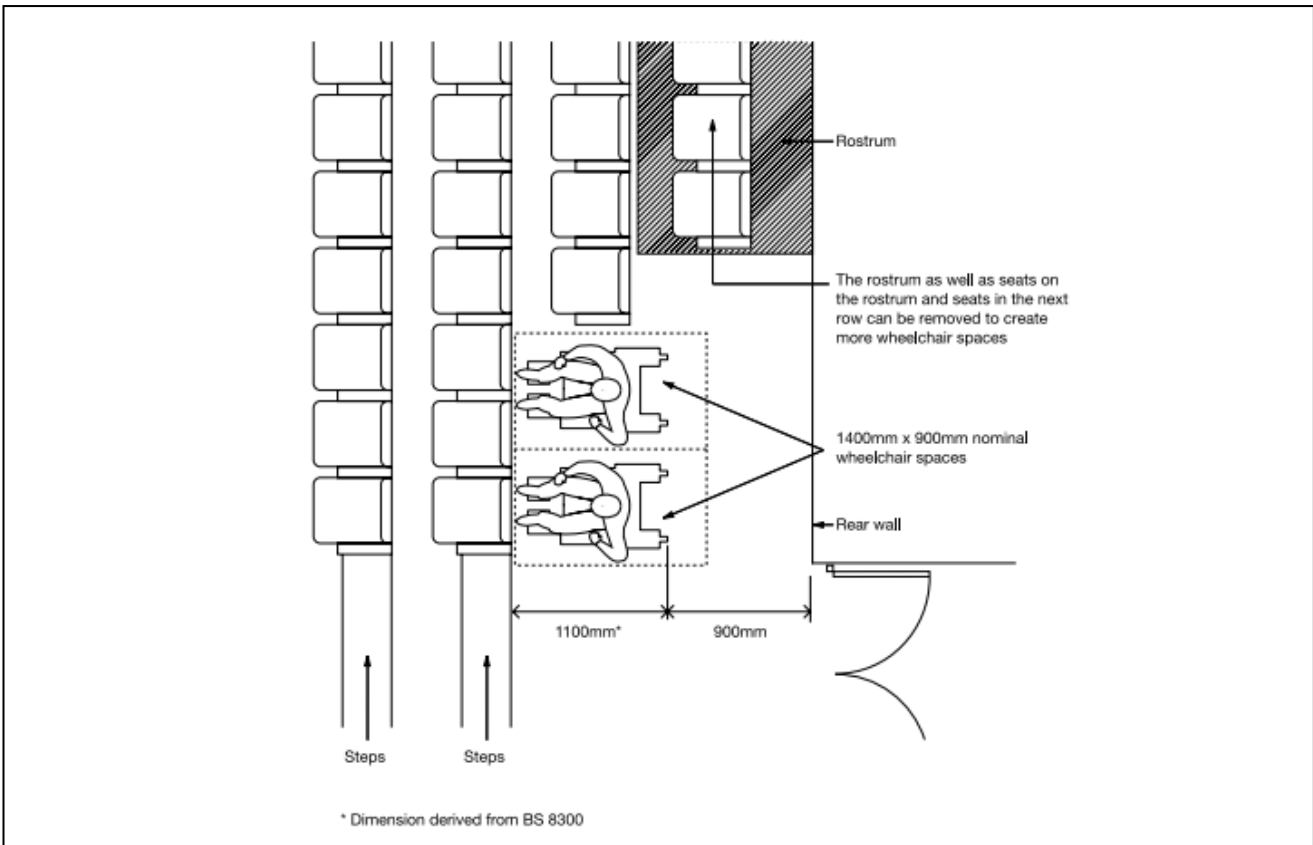
**4.16** Refreshment facilities will satisfy Requirement R1 if:

- a. all users have access to all parts of the facility;
- b. part of the working surface of a bar or serving counter is permanently accessible to wheelchair users, and at level of not more than 850mm above the floor and, where necessary, part at a higher level for people standing;
- c. the worktop of a shared refreshment facility (e.g. for tea making) is at 850mm above the floor with a clear space beneath at least 700mm above the floor (see Diagram 16) and the delivery of water complies with 5.4(a) and (b);
- d. a wheelchair-accessible threshold see 2.7(e) is located at the transition between an external seating area and the interior of the facility.

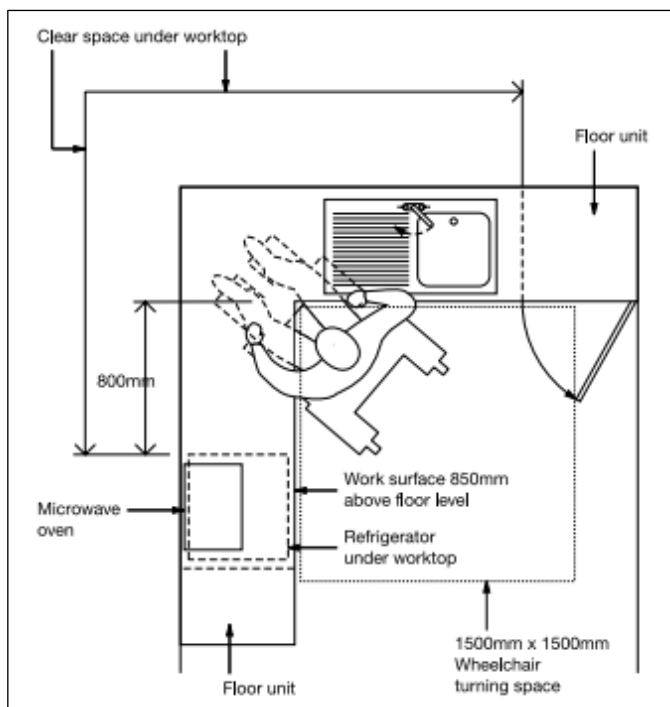
**Diagram 14 Possible location of wheelchair spaces in front of a rear aisle**



**Diagram 15 An example of wheelchair space provision in a cinema or theatre**



**Diagram 16 An example of a shared refreshment facility**



## Sleeping accommodation

### Design considerations

**4.17** Sleeping accommodation, where provided for a significant number of people, e.g. in hotels, motels and student accommodation, should aim to be convenient for all. People who use wheelchairs are likely to require greater provision of space and access to en-suite sanitary accommodation. A proportion of rooms will, therefore, need to accommodate wheelchair users. In student accommodation, it is beneficial to have a wheelchair-accessible toilet available for use by disabled visitors.

**4.18** Wheelchair users should be able to reach all the facilities available within the building. In general, accessible bedrooms should be no less advantageously situated than other bedrooms. It would be beneficial if entrance doors to wheelchair-accessible bedrooms were powered opening, as this

could avoid the need for the 300mm access space adjacent to the leading edge of the door.

**4.19** Wheelchair-accessible bedrooms should be sufficiently spacious to enable a wheelchair user to transfer to one side of a bed, with or without assistance. Wheelchair users should be able to manoeuvre around and use the facilities in the room, and operate switches and controls. They should also be able to gain access to and conveniently use sanitary accommodation and, where provided, balconies. En-suite sanitary facilities are the preferred option for wheelchair-accessible bedrooms. Unless there are compelling reasons for not doing so, there should be at least as many en-suite shower rooms as en-suite shower rooms as en-suite bathrooms, as mobility-impaired people may find it easier to use a shower than a bath. An en-suite shower room or bathroom would benefit from having a finger rinse basin adjacent to the WC, as well as a wash basin or basin in a vanity unit.

**4.20** It is also important to ensure that, in all bedrooms, built-in wardrobes and shelving are accessible and convenient to use. It is an advantage if curtains and blinds are provided with automatic or other remotely controlled opening devices such as rods or pull cords.

**4.21** Wheelchair users should also be able to visit companions in other bedrooms, for example when attending conferences or when on holiday with their families. In these instances, bedrooms not designed for independent use by a person in a wheelchair need to have the outer door wide enough to be accessible to a wheelchair user.

**4.22** For a proportion of wheelchair-accessible bedrooms, it would be useful to provide a connecting door to an adjacent bedroom for a companion.

**4.23** For people with limited manual dexterity, electronic card-activated locks for bedroom entrance doors and lever taps in sanitary accommodation can be an advantage.

## Provisions

**4.24** Sleeping accommodation will satisfy Requirement R1 if:

### *For all bedrooms*

- a. the effective clear width of the door from the access corridor complies with Table 2;
- b. swing doors, where provided for built-in wardrobes and other storage systems, open through 180°;
- c. handles on hinged and sliding doors are easy to grip and operate and contrast visually with the surface of the door;
- d. openable windows and window controls are located between 800 and 1000mm above the floor and easy to operate without using both hands simultaneously;
- e. all bedrooms have a visual fire alarm signal, in addition to the requirements of Part E;
- f. any room numbers are indicated in embossed characters;

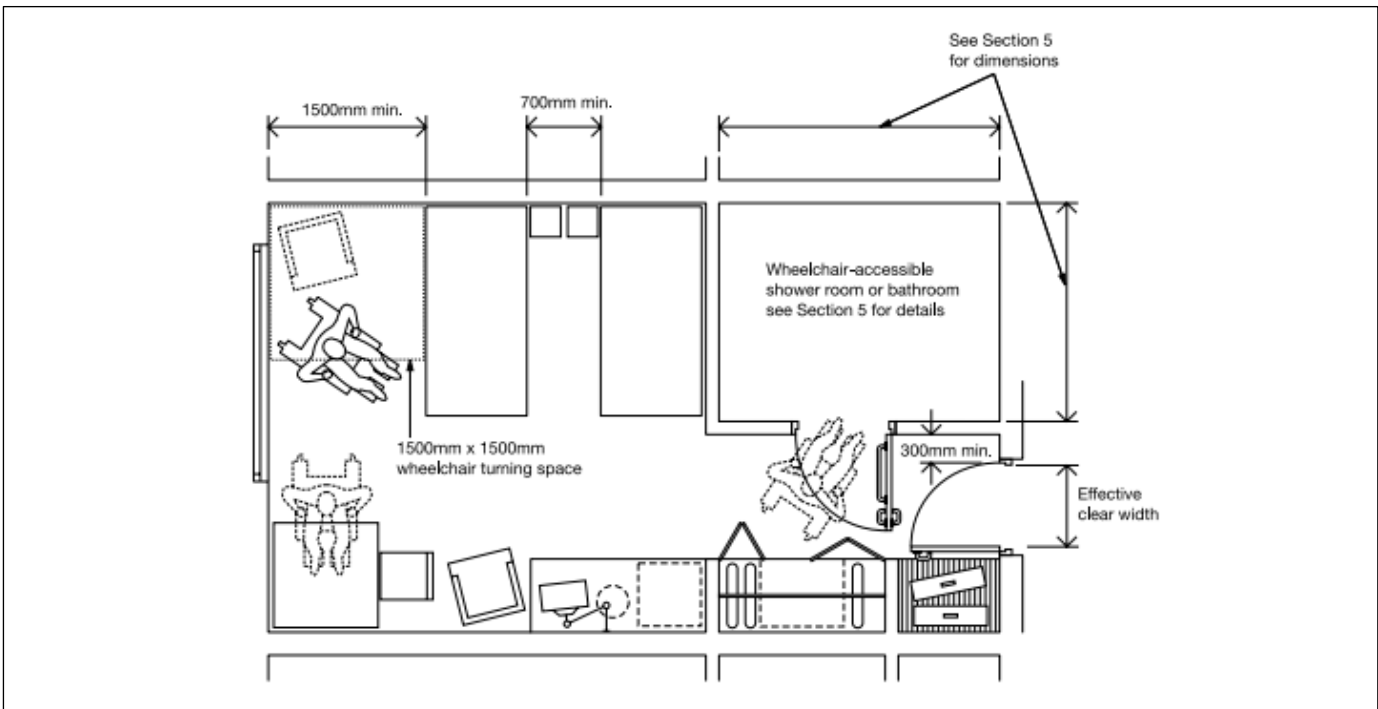
### *For wheelchair-accessible bedrooms*

- g. at least one wheelchair-accessible bedroom is provided for every 20 bedrooms, or part thereof;
- h. wheelchair-accessible bedrooms are located on accessible routes that lead to all other available facilities within the building;
- i. wheelchair-accessible bedrooms are designed to provide a choice of location and have a standard of amenity equivalent to that of other bedrooms;

- j. the door from the access corridor to a wheel-chair accessible bedroom complies with the relevant provisions of 'Internal doors' (see 3.10), in particular the maximum permissible opening force, Table 2 and the need for a clear space of 300mm from the leading edge of the door to the side wall;
- k. the effective clear width of any door to an en-suite bathroom or shower room within the wheelchair-accessible bedroom complies with Table 2;
- l. the size of wheelchair-accessible bedrooms allows for a wheelchair user to manoeuvre at the side of a bed, then transfer independently to it. An example of a wheelchair-accessible bedroom layout is shown in Diagram 17;
- m. sanitary facilities, en-suite to a wheelchair-accessible bedroom, comply with the provisions of 5.15 to 5.21 for 'Wheelchair-accessible bathrooms' or 'Wheelchair-accessible shower facilities';
- n. wide angle viewers, where provided in the entrance door to a wheelchair-accessible bedroom, are located at 1050mm and 1500mm above floor level, to enable viewing by people who are seated or standing;
- o. a balcony, where provided to a wheelchair-accessible bedroom, has a door whose effective clear width complies with Table 2, has a level threshold and has no horizontal transoms between 900mm and 1200mm above the floor;

- p. there are no permanent obstructions in a zone 1500mm back from any balcony doors;
- q. an emergency assistance alarm (together with a reset button) is located in a wheelchair-accessible bedroom and activated by a pull cord, sited so that it can be operated both from the bed and from an adjacent floor area;
- r. an emergency assistance call signal outside an accessible bedroom is located so that it can be easily seen and heard by those able to give assistance and, in any case, at a central control point.

**Diagram 17 One example of wheelchair-accessible hotel bedroom with en-suite sanitary facilities**





## Switches, outlets and controls

### Design considerations

**4.25** The key factors that affect the use of switches, outlets and controls are ease of operation, visibility, height and freedom from obstruction. However, there will be exceptions to height requirements for some outlets, e.g. those set into the floor in open plan offices.

**4.26** A consistent relationship with doorways and corners will further reinforce the ease with which people manipulate switches and controls.

**4.27** All users should be able to locate a control, know which setting it is on and use it without inadvertently changing its setting.

**4.28** Controls that contrast visually with their surroundings are more convenient for visually impaired people, as are light switches that are activated by a large push pad. The colours red and green should not be used in combination as indicators of 'on' and 'off' for switches and controls. It may be useful to use text or a pictogram to clarify the purpose and status of multiple switches and controls.

**4.29** It is also an advantage if individual switches on panels and on multiple socket outlets are well separated, or in the form of large touch plates, to avoid the inadvertent selection of an adjacent control by visually impaired people and people with limited dexterity.

### Provisions

**4.30** Switches, outlets and controls will satisfy Requirement R1 if:

a. wall-mounted socket outlets, telephone points and TV sockets are located between 400mm and 1000mm above the floor, with a preference for the lower end of the range;

- b. switches for permanently wired appliances are located between 400mm and 1200mm above the floor, unless needed at a higher level for particular appliances;
- c. all switches and controls that require precise hand movements are located between 750mm and 1200mm above the floor;
- d. simple push button controls that require limited dexterity are not more than 1200mm above the floor;
- e. pull cords for emergency alarm systems are coloured red, located as close to a wall as possible and have two red 50mm diameter bangles, one set at 100mm and the other set between 800mm and 1000mm above the floor;
- f. controls that need close vision are located between 1200mm and 1400mm above the floor so that readings may be taken by a person sitting or standing (with thermostats at the top of the range);
- g. socket outlets are located consistently in relation to doorways and room corners, but in any case no nearer than 350mm from room corners;
- h. light switches for use by the general public have large push pads and align horizontally with door handles within the range 900 to 1100mm, for ease of location when entering a room;
- i. where switches described in 4.30(h) cannot be provided, lighting pull cords are set between 900mm and 1100mm above floor level, and fitted with a 50mm diameter bangle visually contrasting with its background and distinguishable visually from any emergency assistance pull cord;

- j. the operation of switches, outlets and controls does not require the simultaneous use of both hands, except where this mode of operation is necessary for safety reasons;
- k. switched socket outlets indicate whether they are 'on';
- l. mains and circuit isolator switches clearly indicate that they are on or off;
- m. front plates contrast visually with their backgrounds.

## Aids to communication

### Design considerations

**4.31** People will benefit most if there is an integrated system for wayfinding, public address and hearing enhancement.

**4.32** The appropriate choice of floor, wall and ceiling surface materials and finishes can help visually impaired people appreciate the boundaries of rooms or spaces, identify access routes and receive information. For example, glare and reflections from shiny surfaces, and large repeating patterns, should be avoided in spaces where visual acuity is critical as they will hamper communication for people with impaired vision, and those who lip read or use sign such as reception areas with enquiry desks and speakers' rostrums in lecture halls.

**4.33** The type and quality of public address, hearing enhancement and telephone systems should be chosen carefully to ensure intelligibility. The design of the acoustic environment should also ensure that audible information can be heard clearly.

**4.34** Artificial lighting should be designed to give good colour rendering of all surfaces, without creating glare or pools of bright light and strong shadows. Where appropriate, lighting should illuminate the face of a person

speaking, to make lip reading easier where one-to-one communication is necessary. Uplighters mounted at low or floor level can disorientate some visually impaired people and should be avoided.

**4.35** In order to obtain the full benefit of attending public performances or taking part in discussions, a person with impaired hearing needs to receive a signal that is amplified in both volume and signal to noise ratio. The three systems commonly used to provide this enhanced level of sound are induction loop, infrared and radio. Some field systems are also increasingly being used, particularly in educational establishments. In larger spaces, provision needs to be made for a permanent system, but in small meeting rooms, a portable induction loop would be acceptable. It should be recognized that there is the danger where adjacent spaces each have an induction loop system that the signals may overlap.

Note: Detailed guidance on surface finishes, visual, audible and tactile signs, as well as the characteristics and appropriate choice and use of hearing enhancement systems, is available in BS 8300.

### Provisions

**4.36** Aids to communication will satisfy Requirement R1 if:

- a. a clearly audible public address system is supplemental by visual information;
- b. provision for a hearing enhancement system is installed in rooms and spaces designed for meetings, lectures, classes, performances, spectator sport or films, and at service or reception counters when they are situated in noisy areas or they are behind glazed screens;

- c. the presence of an induction loop or infrared hearing enhancement system is indicated by the standard symbol;
- d. telephones suitable for hearing aid users are clearly indicated by the standard ear and 'T' symbol and incorporate an inductive coupler and volume control;
- e. text telephones for deaf and hard of hearing people are clearly indicated by the standard symbol;
- f. artificial lighting is designed to be compatible with other electronic and radio frequency installations.

---

## Section 5: Sanitary accommodation in buildings other than dwellings

---

### Objectives

**5.1** In principle, suitable sanitary accommodation should be available to everybody, including sanitary accommodation designed for wheelchair users, ambulant disabled people, people of either sex with babies and small children or people encumbered by luggage.

**5.2** In multi-storey buildings, the consistent location of toilets on each floor can help people with learning difficulties to locate these facilities easily.

### Sanitary accommodation generally

#### Design considerations

**5.3** A number of issues need to be considered in connection with all forms of sanitary accommodation. These relate to the needs of people with visual or hearing impairments, people with learning difficulties and people whose lack of tactile sensitivity can cause them to be injured by touching hot surfaces. Taps and WC cubicle doors should be operable by people with limited strength or manual dexterity and doors to cubicles should be capable of being opened if a person has collapsed against them while inside the cubicle. Preferably, all doors to WC cubicles and wheelchair-accessible unisex toilets open out or, if they open in, the door swing should not encroach into the wheelchair turning space or minimum activity space. Where possible, light switches with large push pads should be used in preference to pull cords (see 4.28).

#### Provisions

**5.4** Sanitary accommodation will satisfy Requirement R1 or R3 if:

- a. any bath or washbasin tap is either controlled automatically, or is capable of being operated using a closed fist, e.g. by lever action;
- b. terminal fittings comply with Part B1.
- c. door handles and other ironmongery comply with provisions 3.10 (d) and (e) of 'Internal doors';
- d. WC compartment doors, and doors to wheelchair-accessible unisex toilets, changing rooms or shower rooms are fitted with light action privacy bolts so that they can be operated by people with limited dexterity and, if required to self-close, can be opened using a force no greater than 30N from 0° (the door in the closed position) to 30° open, and not more than 22.5N from 30° to 60° of the opening cycle;
- e. WC compartment doors, and doors to wheelchair-accessible unisex toilets, changing rooms or shower rooms have an emergency release mechanism so that they are capable of being opened outwards, from the outside, in case of emergency;
- f. doors, when open, do not obstruct emergency escape routes;
- g. any fire alarm emits a visual and audible sign to warn occupants with hearing or visual impairments;
- h. any emergency assistance alarm system has:

- i. visual and audible indicators to confirm that an emergency call has been received;
  - ii. a reset control reachable from a wheelchair and the WC, or from the wheelchair and the shower/changing seat;
  - iii. a signal that is distinguishable visually and audibly from the fire alarm.
- i. any lighting controls comply with the provisions for 'Switches and controls', see 4.30;
- j. any heat emitters are either screened or have their exposed surfaces kept at a temperature below 43°C;
- k. the surface finish of sanitary fittings and grab bars contrasts visually with background wall and floor finishes, and there is also visual contrast between wall and floor finishes.

## Provision of toilet accommodation

### Design considerations

**5.5** Toilet accommodation needs to be suitable, not only for disabled people, but for all people who use the building. For disabled people, suitable toilet accommodation may take the form of a specially designed cubicle in separate-sex toilet washrooms, or a self-contained unisex toilet. For wheelchair users in particular, a self-contained unisex toilet is always the preferred option since, if necessary, a partner or carer of a different sex can enter to give assistance. Wheelchair-accessible unisex toilets should always be provided in addition to any wheelchair-accessible accommodation in separate-sex toilet washrooms. Wheelchair-accessible unisex toilets should not be used for baby changing.

**5.6** The provision of an enlarged cubicle in a separate-sex toilet washroom can be of benefit to ambulant disabled people, as well as parents with children and people (e.g. those with luggage) who need an enlarged space. In large building developments, separate facilities for baby changing and an enlarged unisex toilet incorporating an adult changing table are desirable. Facilities incorporating adult changing tables are more commonly known as Changing Places Campaign website ([www.changing-places.org](http://www.changing-places.org)) or by reference to guidance in section 12.7 and Annex G of BS 8300.

**Note:** For specific guidance on the provision of sanitary accommodation in sports buildings, refer to 'Access for Disabled People'.

### Provisions

**5.7** The provision of toilet accommodation will satisfy Requirement R1 or R3 if:

- a. Where there is space for only one toilet in a building, it is of a wheelchair-accessible unisex type, but of greater width to accommodate a standing height wash basin;
- b. at least one wheelchair-accessible unisex toilet is provided at each location in a building where sanitary facilities are provided for use by customers and visitors to a building, or by people working in the building;
- c. at least one WC cubicle is provided in separate-sex toilet accommodation for use by ambulant disabled people;
- d. where there are four or more WC cubicles in separate-sex toilet accommodation, one of these is an enlarged cubicle for use by people who need extra space, in addition to any provision under 5.7(c).

## Wheelchair-accessible unisex toilets

### Design considerations

**5.8** Wheelchair users should be able to approach, transfer to and use the sanitary facilities provided within a building. This requires the provision of a wheelchair-accessible unisex toilet. The relationship of the WC to the finger rinse basin and other accessories should allow a person to wash and dry hands while seated on the WC. The space provided for maneuvering should enable wheelchair users to adopt various transfer techniques that allow independent or assisted use. It is important that the transfer space alongside the WC is kept clear to the back wall. When transferring to and from their wheelchair, some people need horizontal support rails. The rail on the open side is a drop-down rail, but on the wall side, it can be a wall-mounted grab rail (which is thought to give a more rigid handhold) set at a greater distance than normal from the wall or, alternatively, a second drop-down rail in addition to the wall-mounted grab rail where the grab rail is spaced at the minimum distance from the wall and therefore does not give the same degree of support.

**5.9** A unisex toilet is approached separately from other sanitary accommodation. It is more easily identified than a wheelchair-accessible cubicle in a separate-sex toilet washroom and, provided it is used only by disabled people, it is more likely to be available when required. This is particularly important as some disabled people need to use a toilet more frequently than other users. The time needed to reach a wheelchair-accessible toilet should therefore be kept to a minimum when considering the location of unisex toilet accommodation. In addition, a unisex toilet enables one or two assistants of either sex to assist a disabled person. Consideration should be given to installing a chemical sanitary waste disposal unit in wheelchair-accessible WC accommodation. Some wheelchair users find it

difficult to use a standard height WC seat and, for them, it is important that the WC pan can accept a variable height toilet seat riser. WC pans manufactured to the key dimensions given in BS EN 997:2012 WC pans and WC suites with integral trap would be acceptable. are considered acceptable.

**Note:** More detailed guidance on the various techniques used to transfer from a wheelchair to a WC, as well as appropriate sanitary and other fittings, is given in BS 8300.

### Provisions

**5.10** Wheelchair-accessible unisex toilets will satisfy Requirement R1 or R3 if:

- a. one is located as close as possible to the entrance and/or waiting area of the building;
- b. they are not located in any way that compromises the privacy of users;
- c. they are located in a similar position on each floor of a multi-storey building, and allow for right-and left-hand transfer on alternate floors;
- d. when more than one unisex toilet is available in other than multi-storey buildings, a choice of layouts suitable for left-hand transfer is provided;
- e. when it is the only toilet facility in the building, the width is increased from 1.5m to 2m and it includes a standing height washbasin, in addition to the finger rinse basin associated with the WC;
- f. they are located on accessible routes that are direct and obstruction free;

- g. doors are preferably outward opening and are fitted with a horizontal closing bar fixed to the inside face;
- h. any wheelchair user does not have to travel;
- i. more than 40m on the same floor, unless a greater distance can be argued in the Access Statement on the grounds that the circulation route is unobstructed, e.g. by the installation of doors with hold-open devices;
- ii. more than a 40m combined horizontal distance where the unisex toilet accommodation is on another floor of the building, but is accessible by passenger lift (if a lifting platform is installed, vertical travel to a unisex toilet is limited to one storey);
- i. the minimum overall dimensions of, and the arrangement of fittings within, a wheelchair-accessible unisex toilet comply with Diagram 18;
- j. where the horizontal support rail on the wall adjacent to the WC is set with the minimum spacing from the wall, an additional drop-down rail is provided on the wall side at a distance of 320mm from the centre line of the WC.
- k. Where the horizontal support rail on the wall adjacent to the WC is set so that its centre line is 400mm from the centre line of the WC, there is no additional drop-down rail;
- l. The heights and arrangement of fittings in a wheelchair-accessible unisex toilet comply with Diagram 19 and, as appropriate, Diagram 20;
- m. an emergency assistance alarm system is provided, complying with 5.4;
- n. the emergency assistance call signal outside the toilet compartment is located so that it can be easily seen and heard by those able to give assistance;
- o. an emergency assistance pull cord is easily identifiable (see 4.30(e)) and reachable from the WC and from the floor close to the WC;
- p. any heat emitters are located so that they do not restrict the minimum clear wheelchair maneuvering space, nor the space beside the WC used for transfer from the wheelchair to the WC;
- q. WC pans conform to BS 5503-3 or BS 5504-4 in terms of key dimensions in order to accommodate the use of a variable height toilet seat riser (see 5.9);
- r. cisterns for WCs that will be used by wheelchair users have their flushing mechanism positioned on the open or transfer side of the space, irrespective of handing.

Diagram 18 Unisex wheelchair-accessible toilet with corner WC

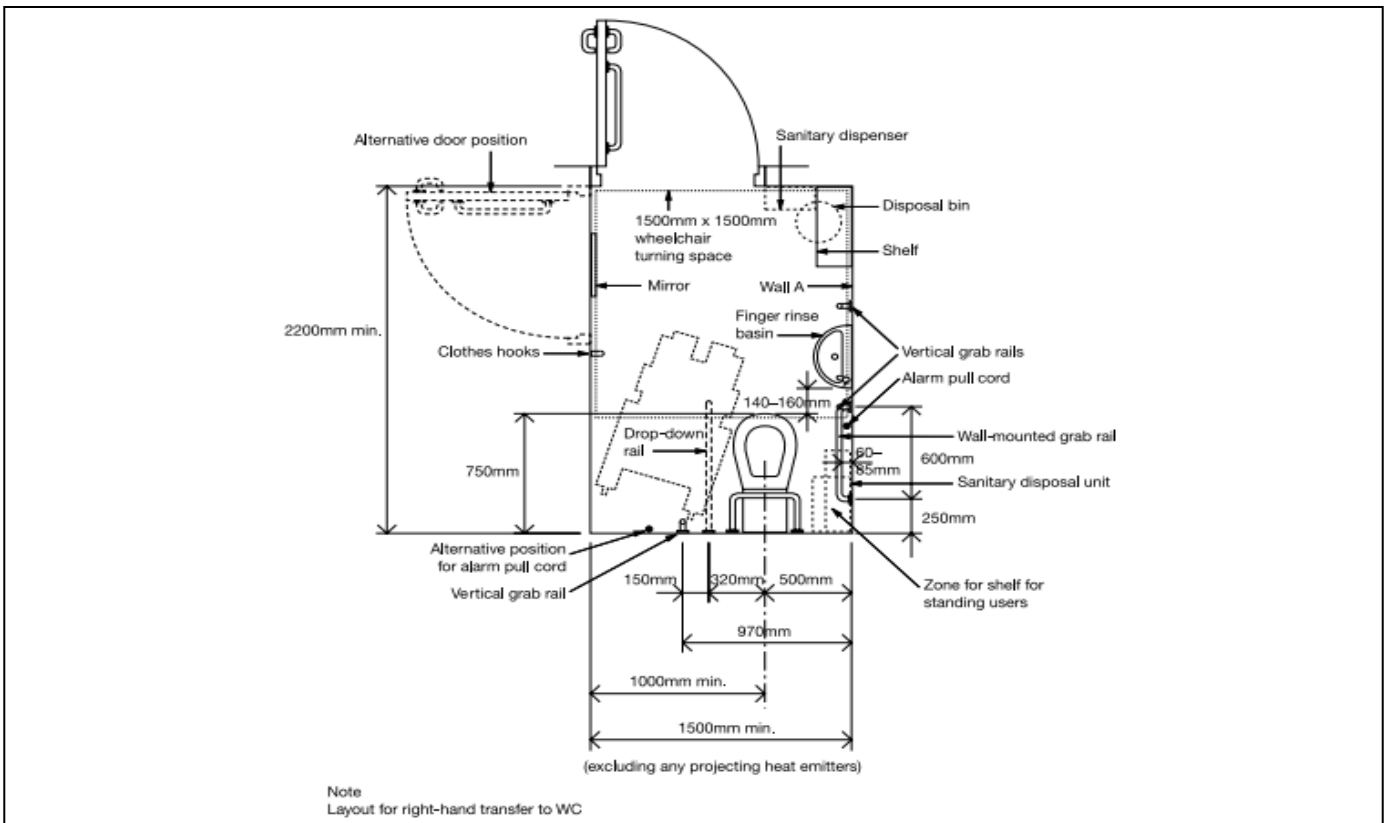
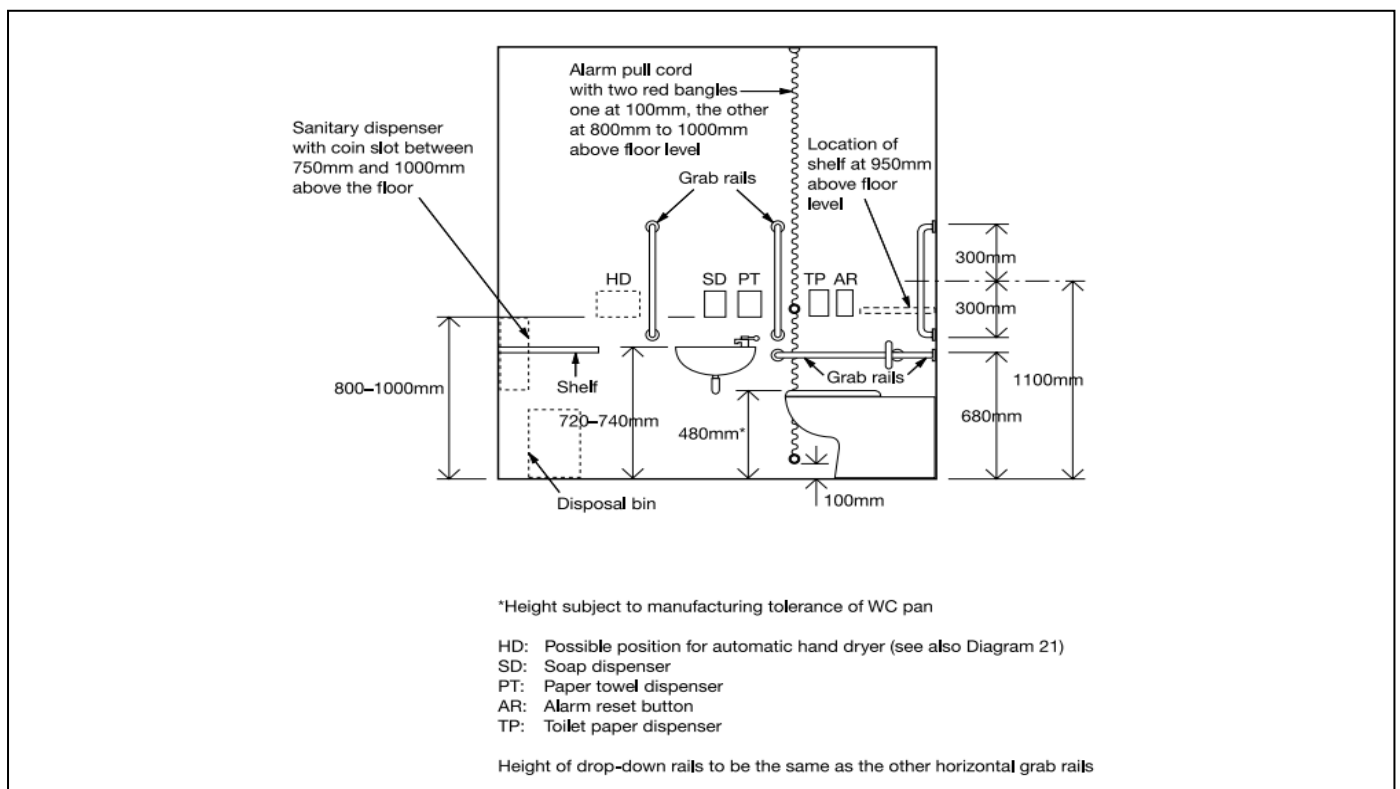
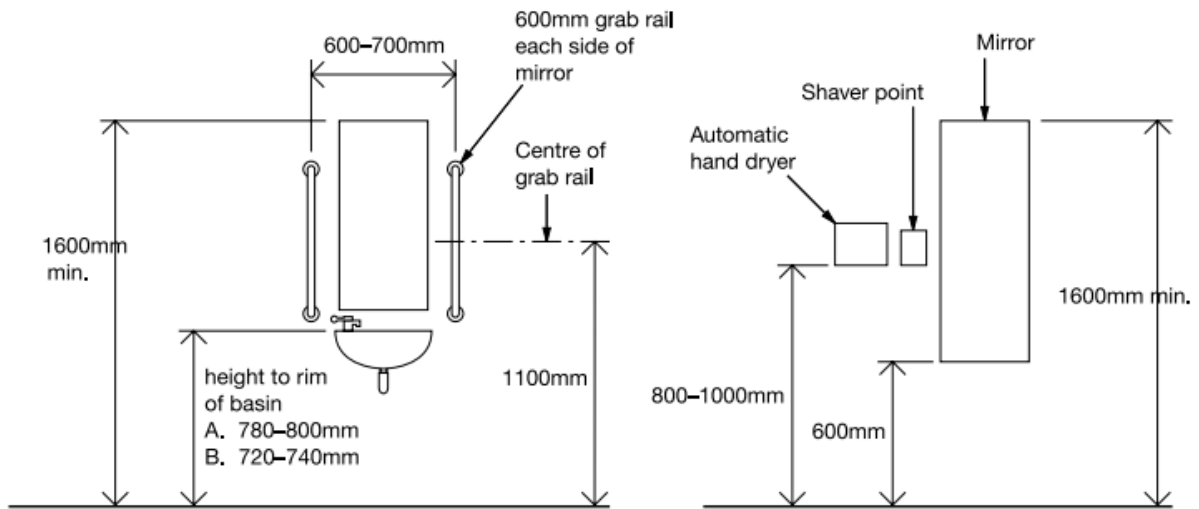


Diagram 19 Heights and arrangement of fittings in a unisex wheelchair-accessible toilet (looking towards wall A in Diagram 18)





**Diagram 20 Heights of various fittings in toilet accommodation**



Height of independent washbasin and location of associated fittings, for wheelchair users and standing people

- A. For people standing
- B. For use from WC

Mirror located away from washbasin suitable for seated and standing people (mirror and associated fittings used within a WC compartment or serving a range of compartments)

## Toilets in separate-sex washrooms

### Design considerations

**5.11** Ambulant disabled people should have the opportunity to use a WC compartment within any separate-sex toilet washroom. The compartment should be fitted with support rails, and include a minimum activity space to accommodate people who use crutches, or otherwise have impaired leg movements. The presence of this facility helps avoid unnecessary travel to unisex toilet accommodation. Some ambulant disabled people find it difficult to use a standard height WC seat and, for them, it is important that the WC pan can accept a variable height toilet seat riser.

**5.12** Separate-sex toilet washrooms above a certain size should also include an enlarged WC cubicle for use by people who need extra space, e.g. parents with children and babies, people carrying luggage and also ambulant disabled people. Consideration should be given to installing a fold-down table, e.g. for baby changing. Standard WC compartments should also have a minimum manoeuvring space clear of any door swing.

**5.13** Where a separate-sex toilet washroom can be accessed by wheelchair users, it should be possible for them to use both a urinal, where appropriate, and a washbasin at a lower height than is provided for other users. The relative numbers of urinals for men and WC compartments for women has been the subject of recent research. In general, the findings indicate that there should be at least the same number of WCs (for women) as urinals (for men) and for some buildings types, e.g. large retail buildings, at least twice as many. Consideration should be given to providing a low level urinal for children in male washrooms.

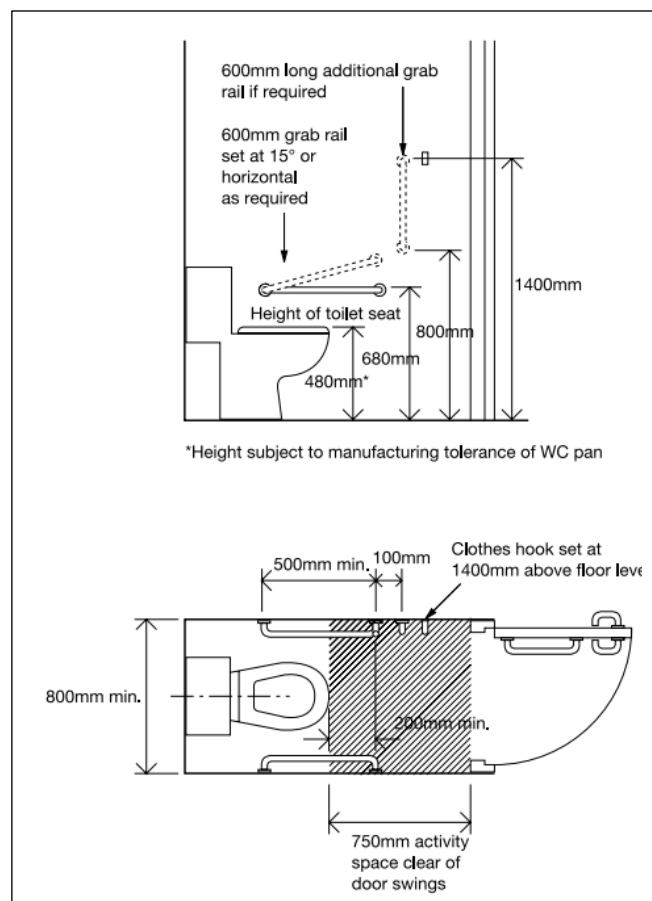
**Note:** More detailed guidance on appropriate sanitary and other fittings is given in BS 8300.

### Provisions

**5.14** WC compartments within separate-sex toilet washrooms will satisfy Requirement R1 of R3 if:

- the swing of any inward opening doors to standard WC compartments is such that a 450mm diameter maneuvering space is maintained between the swing of the door, the WC pan and the side wall of the compartment;
- the minimum dimensions of compartments for ambulant disabled people. Including the activity space, and the arrangement of grab bars and other fittings within the compartment, comply with Diagram 21;

**Diagram 21 WC cubicle for ambulant disabled people**



- c. doors to compartments for ambulant disabled people are preferably outward opening and are fitted with a horizontal; closing bar fixed to the inside face;
- d. an enlarged compartment for those who need extra space (based on the compartment for ambulant disabled people) is 1200mm wide and includes a horizontal grab bar adjacent to the WC, a vertical grab bar on the rear wall and space for a shelf and fold-down changing table;
- e. Any compartment for use by ambulant disabled people has a WC pan that conforms to BS EN 997:2012 in terms of key dimensions, in order to accommodate the use of a variable height toilet seat riser (see 5.9 and 5.11);
- f. a wheelchair-accessible compartment (where provided) has the same layout and fittings as the unisex toilet;
- g. any wheelchair-accessible washroom has at least one washbasin with its rim set at 720 to 740mm above the floor and, for men, at least one urinal with its rim set at 380mm above the floor, with two 600mm long vertical grab bars with their centre lines at 1100mm above the floor, positioned either side of the urinal.

## Wheelchair-accessible changing and shower facilities

### Design considerations

**5.15** A choice of shower layout combined with the correct location of shower controls

and fittings will allow disabled people to use the facilities independently or be assisted by others when necessary. For guidance on the provision of en-suite shower facilities associated with hotel bedrooms, see 4.19.

**5.16** In buildings where changing facilities are associated with showering facilities, many disabled people will be content to use changing and shower areas that are open but provided with subdivisions, whereas some will require the privacy and convenience of an individual self-contained cubicle or compartment. The dimensions of the self-contained compartment allow space for a helper. Any combined facility should be divided into distinct 'wet' and 'dry' areas. In open changing and shower areas, it may be difficult to provide a configuration of handrails, controls and seat suitable for all disabled people to use. Individual self-contained accommodation is therefore preferred although, if it contains a WC, it should not be the only wheelchair-accessible toilet accommodation.

**5.17** In the case of individual changing rooms not associated with showering, e.g. in clothes shops, the dimensions and fittings recommended for an individual self-contained changing cubicle in a sports building should be provided. In large building complexes, such as retail parks and large sports centres, there should be one wheelchair-accessible unisex toilet capable of including an adult changing table.

**Note 1:** For sports buildings, details of different types of changing and shower facilities are given in 'Access for Disabled People'.

**Note 2:** More detailed guidance on appropriate sanitary and other fittings is given in BS 8300.

## Provisions

**5.18** Wheelchair-accessible changing and shower facilities will satisfy Requirement R1 or R3 if:

### *For changing and shower facilities*

- a. a choice of layouts suitable for left-hand and right-hand transfer is provided when more than one individual changing compartment or shower compartment is available;
- b. they are provided with wall-mounted drop-down support rails and wall-mounted slip-resistant tip-up seats (not spring loaded);
- c. in communal shower facilities and changing facilities, they are provided with subdivisions that have the same configuration of space and equipment as for self-contained facilities but without doors;
- d. in sports facilities, individual self-contained shower facilities and changing facilities are available in addition to communal separate-sex facilities;
- e. an emergency assistance pull cord, complying with 4.30(e), is easily identifiable and reachable from the wall-mounted tip-up seat, or from the floor;
- f. an emergency assistance alarm system complying with 5.4(h) is provided;
- g. facilities for limb storage are included for the benefit of amputees;

### *For changing facilities*

- h. the minimum overall dimensions of, and the arrangement of equipment and controls within, individual self-

contained changing facilities comply with Diagram 22;

- i. when associated with shower facilities, the floor of a changing area is level and slip resistant when dry or when wet;
- j. there is a maneuvering space 1500mm deep in front of lockers in self-contained or communal changing areas;

### *For shower facilities*

- k. individual self-contained shower facilities comply with Diagram 23;
- l. where showers are provided in commercial developments for the benefit of staff, at least one wheelchair-accessible shower compartment complying with Diagram 23 should be provided;
- m. a shower curtain, which encloses the seat and the rails when they are in a horizontal position, can be opened from the shower seat;
- n. a shelf that can be reached from the shower seat or from the wheelchair, before or after transfer, is provided for toiletries;
- o. the floor of the shower and shower area is slip resistant and self-draining;
- p. a shower terminal fitting complies with B1;
- q. where wheel-chair accessible shower facilities are available in communal areas, shower controls are positioned between 750 and 1000mm above the floor;

### *For shower facilities incorporating a WC*

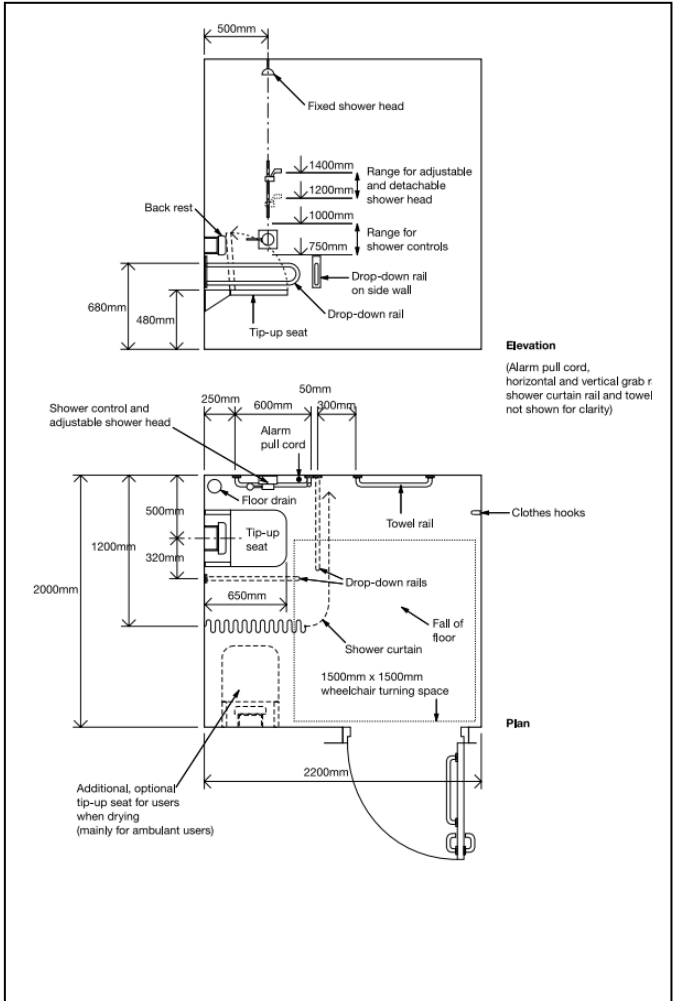
- r. the minimum overall dimensions of, and the arrangement of fittings within, an

individual self-contained shower area incorporating a corner WC, e.g. in a sports building, comply with Diagram 24;

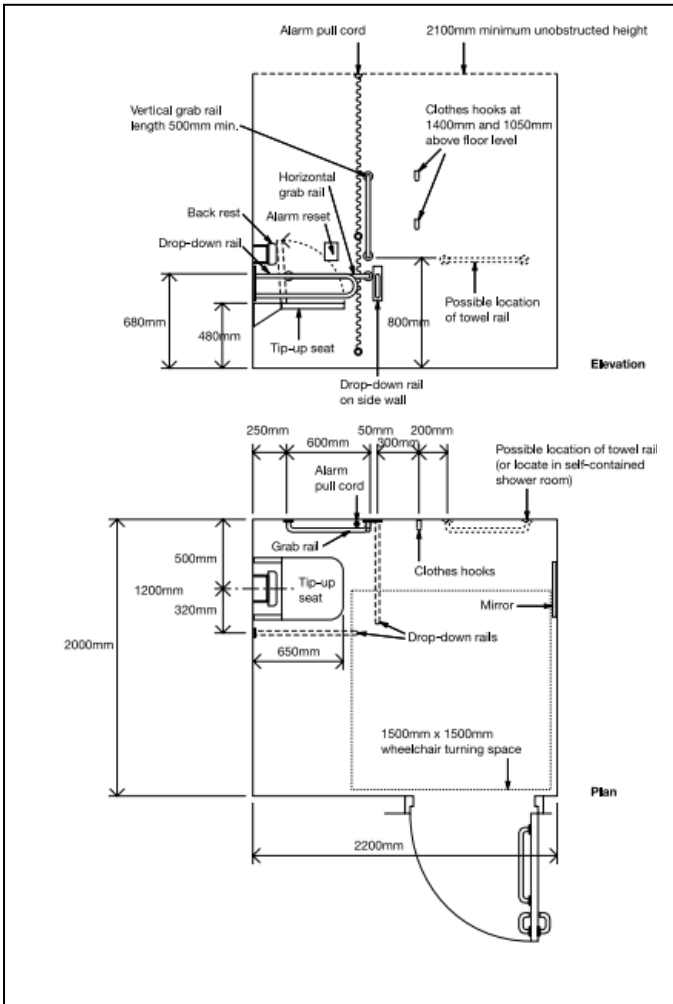
- s. a choice of left-hand and right-hand transfer layouts is available when more than one shower area incorporating a corner WC is provided.

**Note:** Guidance is given in BS 8300.

**Diagram 23 An example of a self-contained shower room for individual use**

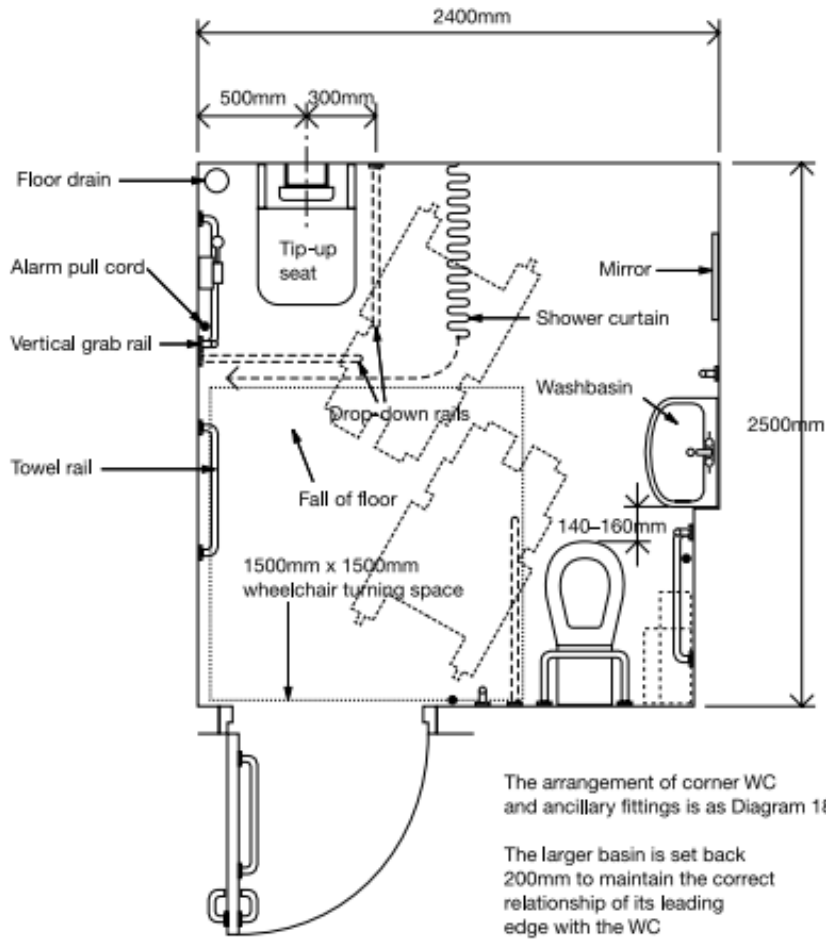


**Diagram 22 An example of a self-contained changing room for individual use**



**Diagram 24 An example of a shower room incorporating a corner WC for individual use**

The arrangement of shower controls and ancillary fittings is as Diagram 23



Note  
Layout shown for right-hand transfer to shower seat and WC

## Wheelchair-accessible bathrooms

### Design considerations

**5.19** Wheelchair users and ambulant disabled people should be able to wash or bathe either independently or with assistance from others. The relationship of the bath to other sanitary fittings, and to the space required for manoeuvring, is therefore critical. Providing a choice of bathroom layout, wherever possible, will meet the needs of many disabled people and help maintain their independence.

**5.20** The guidance covered here applies to wheelchair-accessible bathing facilities where provided in buildings such as hotels, motels, relatives' accommodation in hospitals, and to student accommodation and sports facilities where baths are provided as an alternative, or as a supplement, to showers. For guidance on the provision of en-suite bathrooms associated with hotel bedrooms, see 4.19.

**Note:** More detailed guidance on appropriate sanitary and other fittings, including facilities for the use of mobile and fixed hoists is given in BS 8300.

### Provisions

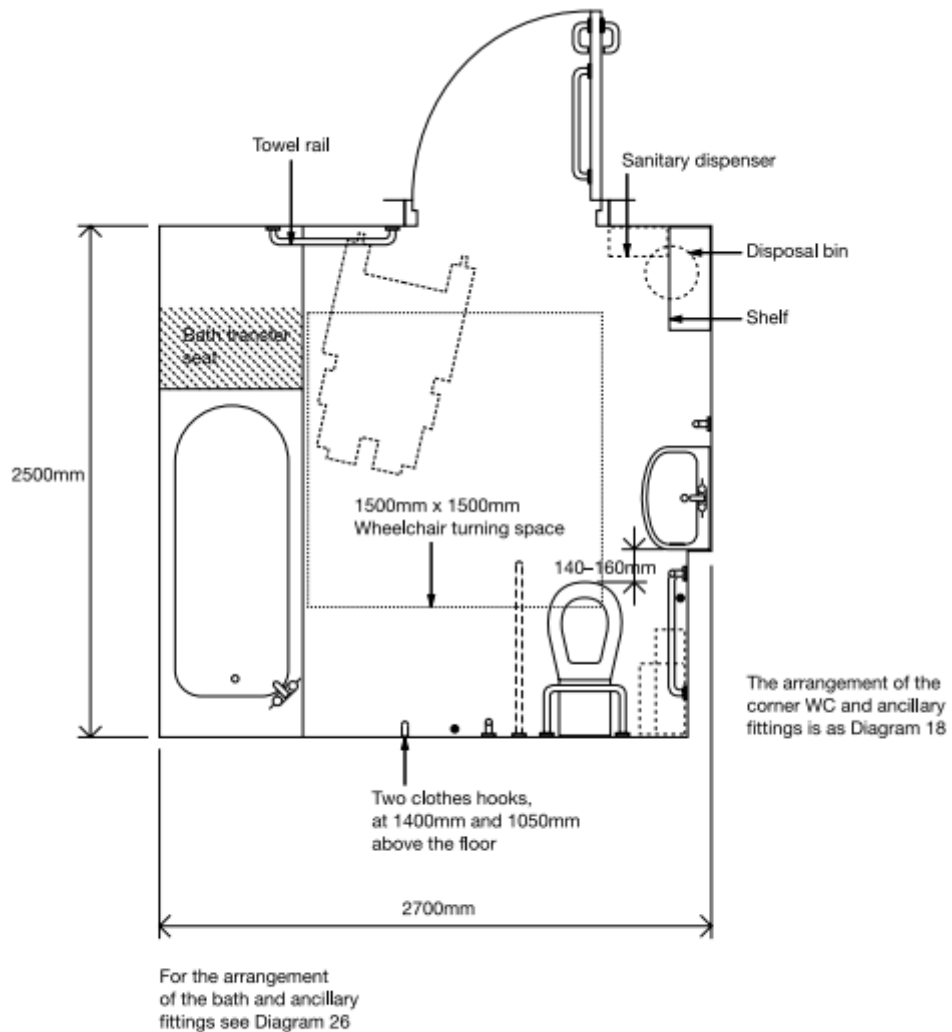
**5.21** Wheelchair-accessible bathrooms will satisfy Requirement R1 or R3 if:

- a. the minimum overall dimensions of, and the arrangement of fittings within, a bathroom for individual use incorporating a corner WC comply with Diagrams 25 and 26;
- b. a choice of layouts suitable for left-hand and right-hand transfer is provided when more than one bathroom for individual use incorporating a corner WC is available;

- c. the floor of a bathroom is slip resistant when dry or when wet;
- d. the bath is provided with a transfer seat, 400mm deep and equal to the width of the bath;
- e. doors are preferably outward opening and are fitted with a horizontal closing bar fixed to the inside face;
- f. an emergency assistance pull-cord complying with 4.30(e) is easily identifiable and reachable from the bath or from the floor;
- g. an emergency assistance alarm system complying with 5.4 (h) is provided.

**Note:** Guidance is given in Annex C of BS8300

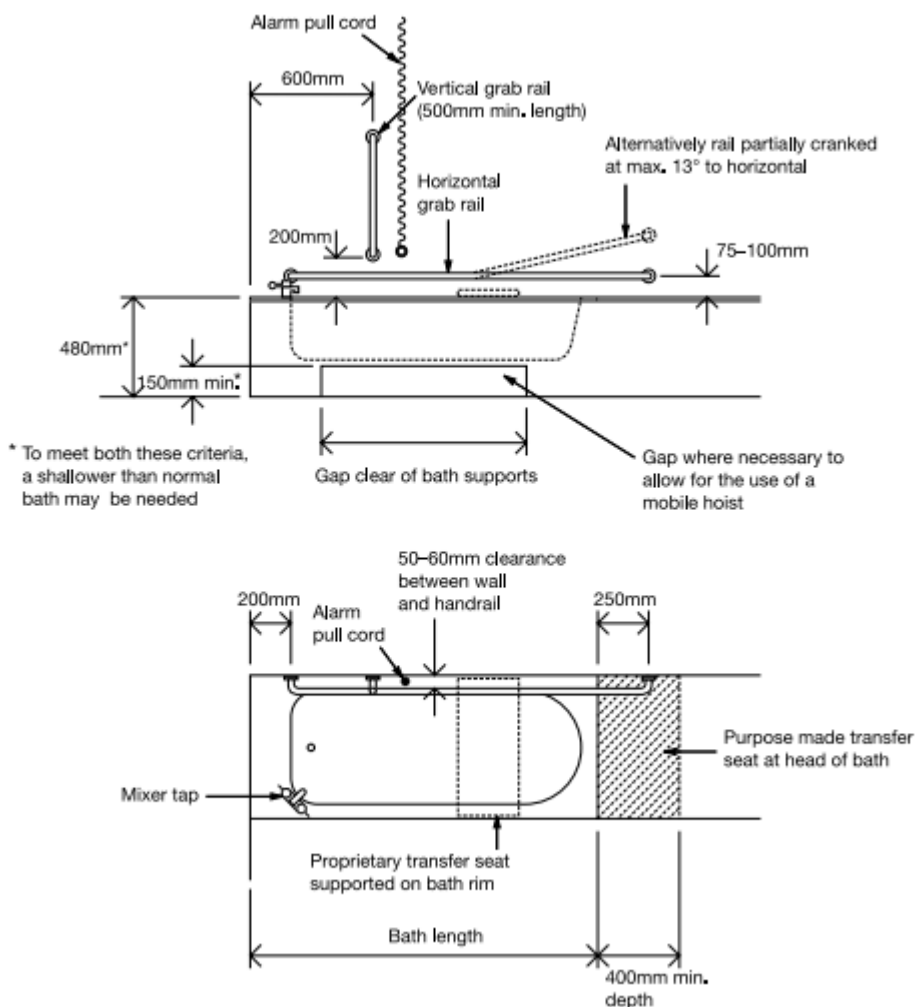
Diagram 25 An example of a bathroom incorporating a corner WC



Note  
Layout shown for right-hand transfer to bath and WC



Diagram 26 Grab rails and fittings associated with a bath



---

## Section 6: Means of access to and into the dwelling

---

### Objective

**6.1** The objective is to make reasonable provision within the boundary of the plot of the dwelling for a disabled person to approach and gain access into the dwelling from the point of alighting from a vehicle which may be within or outside the plot. In most circumstances it should be possible to provide a level or ramped approach.

**6.2** On plots which are reasonably level, wheelchair users should normally be able to approach the principal entrance. Exceptionally for more steeply sloping plots, it is considered reasonable to provide for stick or crutch users (see paragraph 6.9).

**6.3** On plots where wheelchair users have approached the entrance, they should also be able to gain access into the dwelling-house and entrance level flats.

### Approach to the dwelling

#### Design considerations

**6.4** The provision of an approach which can be used by disabled people, including wheelchair users, will often be a matter of practicability. Variations in topography, available plot area or the distance of the dwelling from the point of access may all influence the type of approach that can be provided.

**6.5** Normally, the provisions will apply to the approach to the principal entrance. However, if that is not possible in a particular situation, it would be reasonable to apply them to the approach to a suitable alternative entrance.

**6.6** The approach should be as safe and as convenient for disabled people as is reasonable and, ideally, be level or ramped.

However, on steeply sloping plots, a stepped approach would be reasonable.

**6.7** If a stepped approach to the dwelling is unavoidable, the aim should be for the steps to be designed to suit the needs of ambulant disabled people (see paragraph 6.17).

**6.8** Alternatively, the presence of a driveway might provide a better opportunity for creating a level or ramped approach, particularly if it also provides the sole means of approach for visitors who are disabled. The driveway itself could be designed as the approach from the pavement or footpath or may be the place where visitors park. In such cases, a level or ramped approach may be possible from the car parking space, particularly on steeply sloping plots.

**6.9** It is important that the surface of an approach available to a wheelchair user should be firm enough to support the weight of the user and his or her wheelchair and smooth enough to permit easy manoeuvre. It should also take account of the needs of stick and crutch users. Loose laid materials, such as gravel and shingle, are unsuitable for the approach.

**6.10** The width of the approach, excluding space for a parked vehicle, should take account of the needs of a wheelchair user, or a stick or crutch user (see paragraph 6.13).

**Note:** Account will also need to be taken of planning requirements, such as for new building within conservation areas. Location and arrangement of dwellings on the site is a matter for planning, whereas the internal layout and construction of the dwelling is a matter for building control.

#### Provisions

**6.11** Requirement R1 will be satisfied, if, within the plot of the dwelling, a suitable approach is provided from the point of access to the entrance. The point of access should be

reasonably level and the approach should not have cross-falls greater than 1:40.

**6.12** The whole, or part, of the approach may be a driveway.

### Level approach

**6.13** A 'level' approach will satisfy Requirement R1 if its gradient is not steeper than 1:20, its surface is firm and even and its width is not less than 900mm.

### Ramped Approach

**6.14** If the topography is such that the route from the point of access towards the entrance has a plot gradient exceeding 1:20 but not exceeding 1:15, Requirement R1 will be satisfied if a ramped approach is provided.

**6.15** A ramped approach will satisfy Requirement R1 if it:

- a. has a surface which is firm and even;
- b. has flights whose unobstructed widths are at least 900mm;
- c. has individual flights not longer than 10m for gradients not steeper than 1:15, or 5m for gradients not steeper than 1:12; and
- d. has top and bottom landings and, if necessary, intermediate landings, each of whose lengths is not less than 1.2m, exclusive of the swing of any door or gate which opens onto it.

### Stepped approach

**6.16** If the topography is such that the route (see paragraphs 6.6 – 6.8) from the point of access to the entrance has a plot gradient exceeding 1:15, Requirement R1 will be satisfied if a stepped approach is provided.

**6.17** A stepped approach will satisfy Requirement R1 if:

- a. it has flights whose unobstructed widths are at least 900mm;
- b. the rise of a flight between landings is not more than 1.8m;
- c. it has top and bottom and, if necessary intermediate landings, each of whose lengths is not less than 900mm;
- d. it has steps with suitable tread nosing profiles (see Diagram 27) and the rise of each step is uniform and is between 75mm and 150mm;
- e. the going of each step is not less than 280mm, which for tapered treads should be measured at a point 270mm from the 'inside' of the tread; and
- f. where the flight comprises three or more risers, there is a suitable continuous handrail on one side of the flight. A suitable handrail should have a graspable profile; be between 850mm and 1000mm above the pitch line of the flight; and extend 300mm beyond the top and bottom nosings.

### Approach using a driveway

**6.18** Where a driveway provides a means of approach towards the entrance, it will satisfy Requirement R1 if the driveway provides an approach past and any parked cars in accordance with paragraphs 6.11 – 6.17 above.

### Access into the dwelling

#### Design considerations

**6.19** Where the approach to the entrance consists of a level or ramped approach (see paragraphs 6.13 – 6.15), an accessible

threshold at the entrance should be provided. An accessible threshold into entrance level flats should also be provided.

**6.20** In exceptional circumstances where the approach to the entrance consists of a stepped approach (see paragraph 6.16), it would still be reasonable to provide an accessible threshold. If a step into the dwelling is unavoidable, the rise should be no more than 150mm.

### Provisions

**6.21** If the approach to the dwelling or block of flats consists of a level or ramped approach, Requirement R1 will be satisfied if an accessible threshold is provided into the entrance.

**Note:** General guidance on design considerations for accessible thresholds has been published separately by The Stationery Office as 'Accessible thresholds in new housing; a guidance for house builders and designers'.

## Entrance doors

### Design considerations

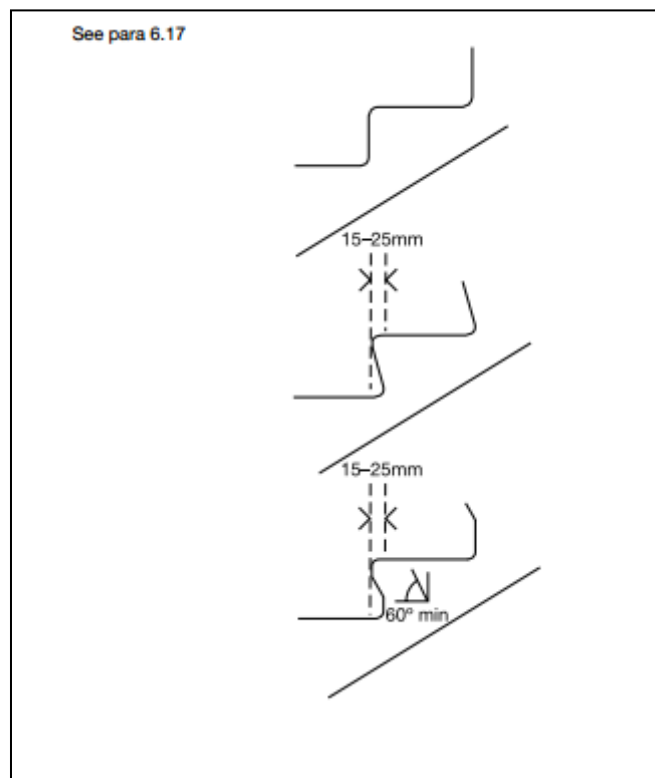
**6.22** The provision of an appropriate door opening width will enable a wheelchair user to manoeuvre into the dwelling.

### Provisions

**6.23** Requirement R1 will be satisfied if an external door providing access for disabled people has a minimum clear opening width of 775mm.

**Note:** For dwellings, the clear opening width is taken from the face of the door stop on the latch side to the face of the door when open at 90°.

Diagram 27 External Step Profile



## Section 7: Circulation within the entrance storey of the dwelling

### Objective

7.1 The objective is to facilitate access within the entrance storey or the principal storey of the dwelling, into habitable rooms and a room containing a WC, which may be a bathroom on that level.

### Corridors, passageways and internal doors within the entrance storey

#### Design considerations

7.2 Corridors and passageways in the entrance storey should be sufficiently wide to allow convenient circulation by a wheelchair user. Consideration should be given to the effects of local obstruction by radiators and other fixtures.

7.3 It will be necessary to consider the layout of a room served by an alternative to the principal entrance in order that a wheelchair user can pass through it to reach the remainder of the entrance storey.

7.4 Internal doors need to be of a suitable width to facilitate wheelchair manoeuvre. A wider door than generally provided would allow easier manoeuvring when it is necessary for a wheelchair user to turn into a door opening, as opposed to approaching it head-on.

#### Provisions

7.5 Requirement R1 will be satisfied if:

- a. a corridor or other access route in the entrance storey or principal storey serving habitable rooms and a room containing a WC (which may be a bathroom) on that level has an unobstructed width in accordance with Table 4;

- b. a short length (no more than 2m) of local permanent obstruction in a corridor, such as a radiator, would be acceptable provided that the

unobstructed width of the corridor is not less than 750mm for that length,

and the local permanent obstruction is not placed opposite a door to a room if it would prevent a wheelchair user turning into or out of the room; see Diagram 28 and

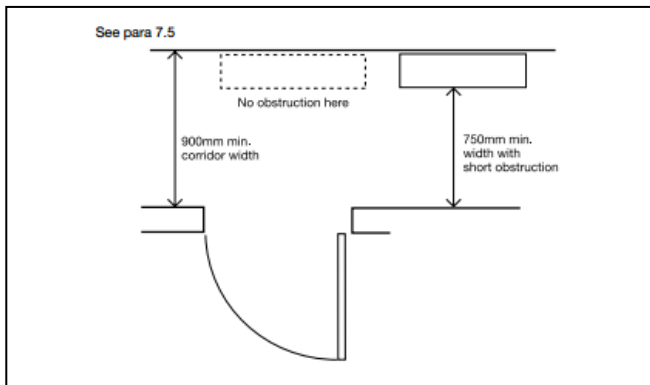
- c. doors to habitable rooms and a room containing a WC have minimum clear opening widths shown in Table 4, when accessed by corridors or passageways whose widths are in accordance with those listed in Table 4.

Table 4 shows the minimum widths of corridors and passageways that would be necessary to enable wheelchair users to turn into and out of a range of doorway widths.

**Table 4 Minimum width of corridors and passageways for a range of doorway width**

Doorway clear opening Width (mm)	Corridor/Passageway width (mm)
750 or wider	800 (when approach head-on)
750	1200 (when approach not head-on)
775	1050 (when approach not head-on)
800	900 (when approach not head-on)

## Diagram 28 Corridors, passages and internal doors



### Vertical circulation within the entrance storey

#### Design considerations

**7.6** In exceptional circumstances, where severely sloping plots are involved, a stepped change of level within the entrance storey may be unavoidable. In those instances, the aim should be to provide a stair of reasonable width for ambulant disabled people to negotiate the steps with assistance and for handrails on both sides. Part H of the Building Rules 2017 contains guidance on the design of stairs in dwellings.

#### Provisions

**7.7** A stair providing vertical circulation within the entrance storey of the dwelling will satisfy Requirement R1 if;

- a. it has flights whose clear widths are at least 900mm;
- b. there is a suitable continuous handrail on each side of the flight and any intermediate landings where the rise of the flight comprises three or more risers; and
- c. the rise and going are in accordance with the guidance in the Table to Rule H3 of Part H for stairs.

---

## Section 8: Accessible switches and socket outlets in the dwelling

---

### Objective

**8.1** The aim is to assist those people whose reach is limited to use the dwelling more easily by locating wall-mounted switches and socket outlets at suitable heights.

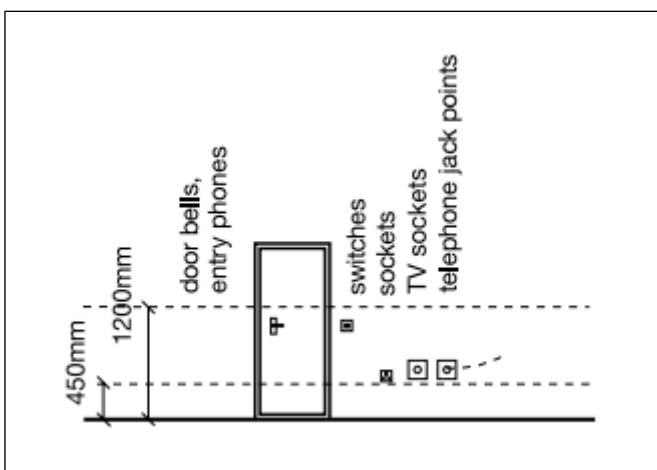
### Design considerations

**8.2** Switches and socket outlets for lighting and other equipment should be located so that they are easily reachable.

### Provisions

**8.3** A way of satisfying Requirement R1 would be to provide switches and socket outlets for lighting and other equipment in habitable rooms at appropriate heights between 450mm and 1200mm from finished floor level (see Diagram 29).

**Diagram 29** Heights of switches, sockets, etc.



## Section 9: Passenger lifts and common stairs in blocks of flats

### Objectives

**9.1** For buildings containing flats, the objective shall be to make reasonable provision for disabled people to visit occupants who live on any storey.

**9.2** The most suitable means of access for disabled people from one storey to another is a passenger lift.

### Design Considerations

**9.3** Where a lift is provided, as a minimum a utility stair should be designed to be suitable for people with impaired sight. The lift should conform to the relevant British Standards, EN 81 series of standards, in particular BS EN 81-70:2003 Safety Rules for the construction and installation of lifts or, where necessary by product certification issued by a Notified Body). Be suitable for an unaccompanied wheelchair user. Suitable provision should also be made for people with sensory impairments. Measures should also be adopted which give a disabled person sufficient time to enter the lift to reduce the risk of contact with closing doors.

### Provisions

#### Common stairs

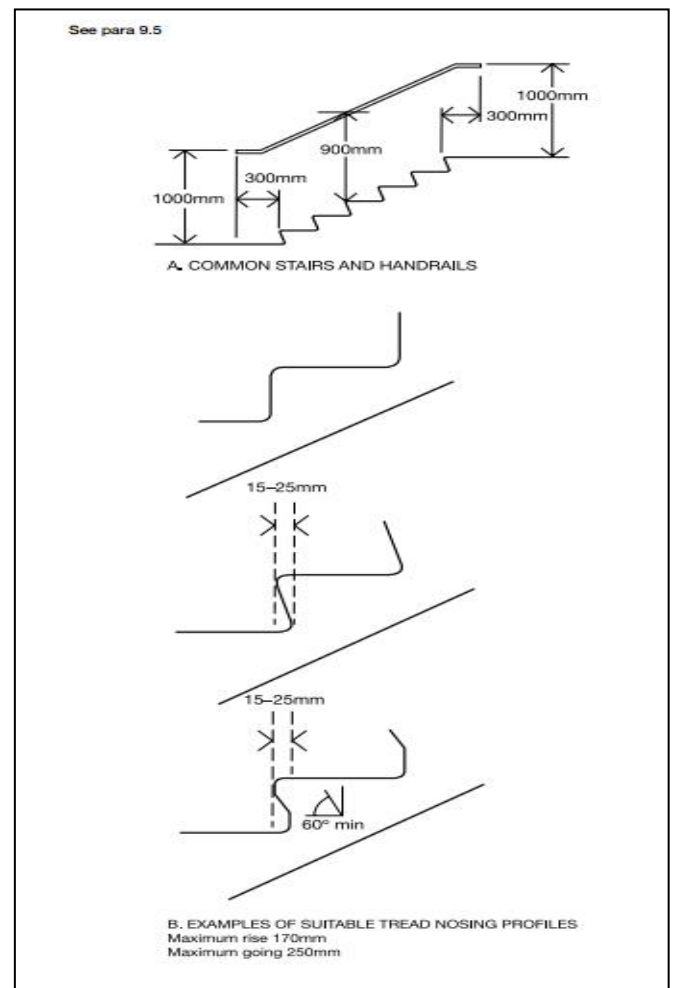
**9.4** Requirement R1 will be satisfied if a building containing flats, is provided with a suitable stair, which has:

- all step nosings distinguishable through contrasting brightness;
- top and bottom landings whose lengths are in accordance with Part K1;
- steps with suitable tread nosing profiles (see Diagram 30) and

uniform rise of each step, which is not more than 170mm;

- uniform going of each step, which is not less than 250mm, which for tapered treads should be measured at a point 270mm from the inside of the tread;
- risers which are not open; and
- a suitable continuous handrail on each side of flights and landings if the rise of the stair comprises two or more rises.

**Diagram 30 Common stairs in blocks of flats**





## Lifts

**9.5** Requirement R1 will be satisfied if a building, or a part of a building which contains flats above the entrance storey and in which passenger lift access is to be installed, is provided with a suitable passenger lift with a minimum load capacity of 400kg.

**9.6** One way of satisfying Requirement R1 would be to provide a passenger lift, see 3.34 (a) and which:

- a. has a clear landing at least 1500mm wide and at least 1500mm long in front of its entrance;
- b. has a door or doors which provide a clear opening width of at least 800mm;
- c. has a car whose width is at least 900mm and whose length is at least 1250mm (other dimensions may satisfy Requirement R1 where shown be test evidence or experience in use, or otherwise, to be suitable for an unaccompanied wheelchair user);
- d. has landing and car opening which are not less than 900mm and not more than 1200mm above the landing and the car floor, at a distance of at least 400mm from the front wall;
- e. is accompanied by suitable tactile indication on the landing and adjacent to the lift call button to identify the storey in question;
- f. has suitable tactile indication on or adjacent to lift buttons within the car to confirm the floor selected;
- g. incorporates a signalling system which gives visual notification that the lift is answering a landing call

and a 'dwell time' of five seconds before its doors begin to close after they are fully open: the system may be overridden by a door re-activating device which relies on appropriate electronic methods, but not a door edge pressure system, provided that the minimum time for a lift door to remain fully open is 3 seconds; and

- h. when the lift serves more than three storeys, incorporates visual and audible indication of the floor reached.

## Section 10: WC provision in the entrance storey of the dwelling

### Objectives

**10.1** The primary objective is to provide a WC in the entrance storey of the dwelling and to locate it so that there should be no need to negotiate a stair to reach it from the habitable rooms in that storey. Where the entrance storey contains no habitable rooms, it is reasonable to provide a WC in either the entrance storey or the principal storey.

### Design considerations

**10.2** The aim is to provide a WC within the entrance storey or the principal storey of a dwelling. Where there is a bathroom in that storey, the WC may be located in that bathroom. It will not always be practical for the wheelchair to be fully accommodated within the WC compartment.

### Provision

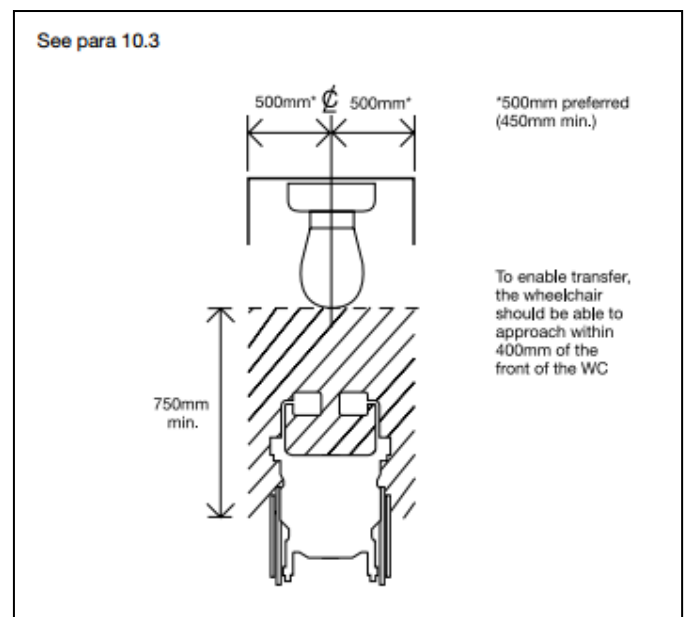
**10.3** Requirement R4 will be satisfied, if:

- a WC is provided in the entrance storey of a dwelling which contains a habitable room; or where the dwelling is such that there are no habitable rooms in the entrance storey, if a WC is provided in either the entrance storey or the principal storey;
- the door to the WC compartment opens outwards, and is potential to enable wheelchair users to access the WC and has a clear opening width in accordance with Table 4 (door openings wider than the minimum in Table 4 allow easier manoeuvring and access to the WC by wheelchair users); and

- the WC compartment provides a clear space for wheelchair users to access the WC (see Diagrams 31 and 32) and the

washbasin is positioned so that it does not impede access.

**Diagram 31 Clear space for frontal access to WC**



**Diagram 32 Clear space for oblique access to WC**

